

FURUNO

INSTALLATION MANUAL

MARINE RADAR/ARPA

MODEL FAR2167DS-BB







FURUNO ELECTRIC CO., LTD.
NISHINOMIYA, JAPAN



SAFETY INSTRUCTIONS

The installer must read and follow all the safety instructions before attempting to install the equipment.

 WARNING	Indicates a potentially hazardous situation which, if not avoided, could result in death or serious injury.
 CAUTION	Indicates a potentially hazardous situation which, if not avoided, may result in minor or moderate injury.

 Warning, Caution	 Prohibitive Action	 Mandatory Action
--	--	--

WARNING

Radio Frequency Radiation Hazard



The radar antenna emits electromagnetic radio frequency (RF) energy which can be harmful, particularly to your eyes. Never look directly into the antenna aperture from a close distance while the radar is in operation or expose yourself to the transmitting antenna at a close distance.

Distances at which RF radiation levels of 100 W/m² and 10 W/m² exist are given in the table below.

Note: If the antenna unit is installed at a close distance in front of the wheel house, it may be necessary to halt transmission within a certain sector of antenna revolution. This can be done from the SCANNER menu.

Radiator type	Distance to 100 W/m ² point	Distance to 10 W/m ² point
SN30AF	0.60 m	8.90 m
SN36AF	0.40 m	7.40 m

WARNING



Do not open the equipment unless totally familiar with electrical circuits and service manual.

Only qualified personnel should work inside the equipment.



Wear a hard hat and safety belt when mounting the antenna unit.

Serious injury or death can result if someone falls from the radar antenna mast.



Construct a suitable service platform from which to install the antenna unit.

Serious injury or death can result if someone falls from the radar antenna mast.



Do not install units other than the antenna unit in a place subject to rain or water splash.

Fire, electrical shock or injury can result if water leaks into those units.



Turn off the power at the switchboard before beginning the installation.

Fire, electrical shock or injury can result if the power is on during the installation.



Use only the specified power cables.

Use of power cables that are thinner than those specified can cause fire.



Securely attach protective earth to the ship's body.

The protective earth is required to prevent electrical shock.

CAUTION



A proper license is necessary to install a radar.

See your dealer for details.



Observe the following compass safe distances to prevent interference to a magnetic compass:

	Standard compass	Steering compass
Antenna Unit (50 kw)	3.75 m	2.45 m
Monitor Unit (MU-201CR)	1.55 m	1.00 m
Processor Unit (RPU-013)	1.35 m	0.85 m
Control Unit (RCU-014)	0.30 m	0.30 m
Control Unit (RCU-015)	0.95 m	0.60 m
Control Unit (RCU-016)	0.65 m	0.45 m
Power Supply Unit (PSU-006)	0.30 m	0.30 m
Memory Card Interface Unit (CU-200)	0.90 m	0.60 m
Switching Hub (HUB-100)	1.00 m	0.60 m

TABLE OF CONTENTS

- SYSTEM CONFIGURATION.....iv**
- EQUIPMENT LISTSv**

- 1. MOUNTING 1-1**
 - 1.1 Antenna Unit..... 1-1
 - 1.2 Monitor Unit (for FAR-2167DS)..... 1-7
 - 1.3 Control Unit 1-10
 - 1.4 Processor Unit..... 1-15
 - 1.5 Power Supply Unit..... 1-16

- 2. WIRING 2-1**
 - 2.1 Wiring Overview 2-1
 - 2.2 Antenna Unit..... 2-2
 - 2.3 Monitor Unit (for FAR-2167DS)..... 2-7
 - 2.4 Processor Unit..... 2-8
 - 2.5 Power Supply Unit..... 2-13
 - 2.6 Changing AC Power Specification 2-15

- 3. ADJUSTMENTS 3-1**
 - 3.1 Initializing Tuning..... 3-1
 - 3.2 Heading Alignment..... 3-2
 - 3.3 Adjusting Sweep Timing..... 3-5
 - 3.4 Suppressing Main Bang 3-6
 - 3.5 Other Settings 3-7

- 4. OPTIONAL EQUIPMENT 4-1**
 - 4.1 Gyro Converter GC-10 4-1
 - 4.2 Memory Card Interface Unit..... 4-10
 - 4.3 DVI-RGB Conversion Kit..... 4-13
 - 4.4 BNC Connector Converter 4-16

- 5. IO DATA..... 5-1**

- PACKING LISTSA-1**
- OUTLINE DRAWINGSD-1**
- INTERCONNECTION DIAGRAM.....S-1**

SYSTEM CONFIGURATION

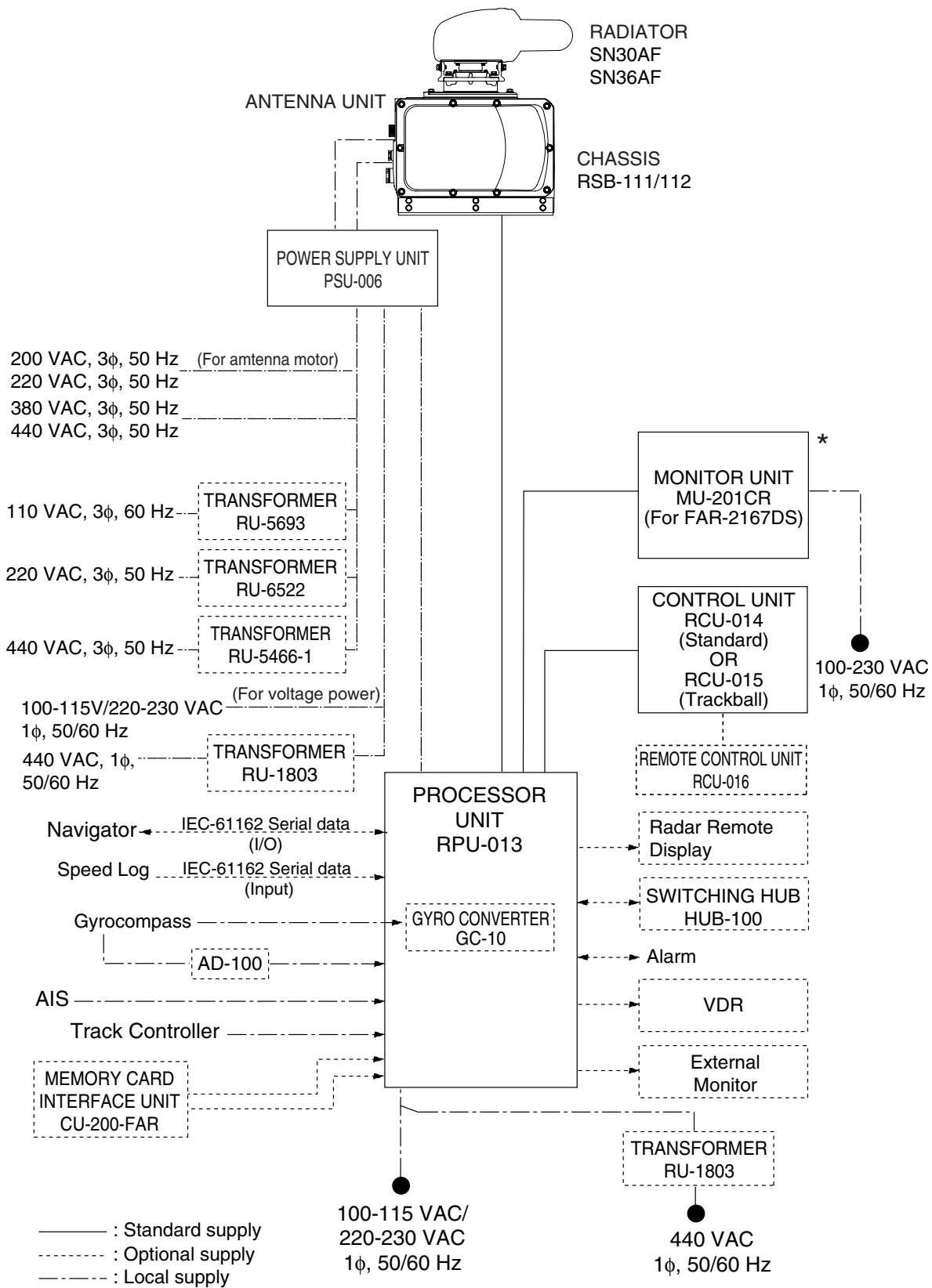

* FAR-2167DS-BB is not equipped with a monitor unit. Procure one locally.

Equipment category

Unit	Category
Antenna	Exposed to weather
Other units	Protected from weather

EQUIPMENT LISTS

Standard supply

Name	Type	Code No.	Qty	Remarks
Antenna Unit	SN30AF	–	1	Radiator
	SN36AF	–		
	RSB-111	–	1	200 VAC, 3 ϕ , 50 Hz 220 VAC, 3 ϕ , 60 Hz Chassis
	RSB-112	–		
Power Supply Unit	PSU-006	–	1	
Monitor Unit	MU-201CR	–	1	For FAR-2167DS
Processor Unit	RPU-013	–	1	
Control Unit	RCU-014	–	1	Standard-type
	RCU-015	–		Trackball-type
Installation Materials*	CP03-31501	008-573-780	1	For antenna unit
	CP03-25700	000-080-435	1	15 m signal cable (RW-9600)
	CP03-25710	000-080-436		30 m signal cable (RW-9600)
	CP03-25730	000-082-191		40 m signal cable (RW-9600)
	CP03-25720	000-080-437		50 m signal cable (RW-9600)
	CP03-25800	000-080-434	1	Cable assy. for monitor unit
	CP03-25602	008-535-940	1	For processor unit
	CP03-31401	008-572-750	1	For power supply unit
	CP03-25604	008-539-850	1	For control unit
Accessories*	FP03-09810	008-536-010	1	For monitor unit.
	FP03-09850	008-535-610	1	For standard-type control unit
	FP03-09860	008-535-690		For trackball-type control unit
	FP03-10101	008-538-730	1	For antenna unit
Spare Parts*	SP03-14404	008-535-910	1	For processor unit, 100 VAC
	SP03-14405	008-535-920		For processor unit, 220 VAC
	SP03-14401	008-535-990	1	For monitor unit
	SP03-15501	008-572-730	1	For power supply unit, 100 VAC
	SP03-15502	008-572-740		For power supply unit, 220 VAC

* See packing list at end of this manual.

Optional equipment

Name	Type	Code No.	Remarks
Gyro Converter	GC-10-2	000-080-440	See Chapter 4.
Stepdown Transformer Unit	RU-1803	–	440 to 100 VAC, for processor unit
	RU-5693	–	110 to 220 VAC, 3 ϕ , for antenna unit
	RU-6522	–	220 to 200 VAC, 3 ϕ , for antenna unit
	RU-5466-1	–	440 to 200 VAC, 3 ϕ , for antenna unit
Radar Remote Display	FMD-8010	–	
Memory Card Interface Unit	CU-200-FAR	000-081-568	w/CP03-27430, see Chapter 4.
External Alarm Buzzer	OP03-21	000-030-097	
Remote Control Unit	RCU-016	000-080-299	Remote type, w/FP03-09860
RAM Card	O0RAM08MC-005	004-376-740	8MB
DVI-RGB Converter Kit	OP03-180-2	008-536-070	See Chapter 4.
Cable Assy.	XH10P-W-6P L=20M	000-149-748	Processor unit \leftrightarrow Control unit, 20 m
	XH10P-W-6P L=30M	000-149-749	Processor unit \leftrightarrow Control unit, 30 m
	XH10P-W-5P-A L=10M	000-149-050	Between control units, 10 m
	XH10P-W-5P-A L=20M	000-149-051	Between control units, 20 m
	XH10P-W-5P-A L=30M	000-149-052	Between control units, 30 m
	DVI-D/D S-LINK 10M	000-150-200	Processor unit \leftrightarrow Control unit, 10 m
	S03-9-5(8-8P)	008-206-640	External radar, 5 m, 8-8P
	S03-9-10(8-8P)	008-206-650	External radar, 10 m, 8-8P
	S03-9-15(8-8P)	008-209-160	External radar, 15 m, 8-8P
Installation Materials (Armored LAN-Cable Kit)	CP03-28900	000-082-658	FR-FTPC-CY 10 m, modular connector MPS588-C, 2 pcs.
	CP03-28910	000-082-659	FR-FTPC-CY 20 m, modular connector MPS588-C, 2 pcs.
	CP03-28920	000-082-660	FR-FTPC-CY 30 m, modular connector MPS588-C, 2 pcs.
Bracket Assy.	FP03-09820	008-535-560	Hanger assy. for monitor unit
Handgrip Assy.	FP03-09840	008-535-570	For monitor unit
Dust Cover	03-163-1201	100-307-260	For monitor unit
Clamp Assy.	OP03-182	008-535-620	For RCU-014
Flush Mount Kit	FP03-09870	008-535-630	For control unit
Connection Stand	OP03-183	008-535-640	RCU-014 \leftrightarrow MU-201CR
	OP03-185	008-535-660	RCU-014
Hanger Kit	FP03-10201	008-539-530	Desktop inst. kit for CU-200-FAR
BNC Connector Converter	DSUB-BNC-1	000-148-528	For connecting VDR
Switching Hub	HUB-100	–	See Operator's Manual for HUB-100, issued separately.

1. MOUNTING

1.1 Antenna Unit

Mounting considerations

The antenna unit is generally installed either on top of the wheelhouse, on the radar mast, or on a suitable platform. The mounting location should afford a good all-round view and satisfy the siting and mounting considerations mentioned below.

Siting

- No funnel, mast or derrick should be within the vertical beamwidth of the antenna unit in the bow direction, especially zero degrees $\pm 5^\circ$, to prevent blind sectors and false echoes on the radar picture.
- Deposits and fumes from a funnel or other exhaust vent can adversely affect the aerial performance and hot gases may deform the radiator. The antenna unit must not be mounted where the temperature is more than 70°C.
- Locate a direction finder antenna clear of the antenna unit to prevent interference to the direction finder. A separation of more than two meters is recommended.
- Choose a location where reflections from the radar reflector will not be received by the radar antenna.
- The "standard" antenna unit orientation has the cable glands directed toward the bow.
- Leave sufficient space around the unit for maintenance and servicing. See the antenna unit outline drawing for recommended maintenance space.

Mounting

- Use rope and crane to hoist the antenna unit to the mounting location. Lifting fixtures are provided on the antenna chassis to which to fasten rope.
- Mount the unit parallel to the waterline.
- A hole is required in the mounting platform for the antenna cable.
- An appropriate platform should be constructed at the mounting location to facilitate installation and maintenance work.
- Connect ground wire between antenna terminal on antenna chassis and ground point.
- If the mounting platform is made of steel paint it to prevent electrolytic corrosion. DO NOT paint the antenna radiator.

Installation precaution for S-band antenna unit

If an S-band antenna unit is mounted near the end of a platform to provide sufficient rotation clearance for the radiator, the antenna unit, because of its weight, will swing up and down by ship's vibration and rolling. This exerts excessive levels of stress at the base of the radiator, which can damage the radiator. To prevent this, relocate the antenna unit, or if relocation is not possible reinforce the platform.

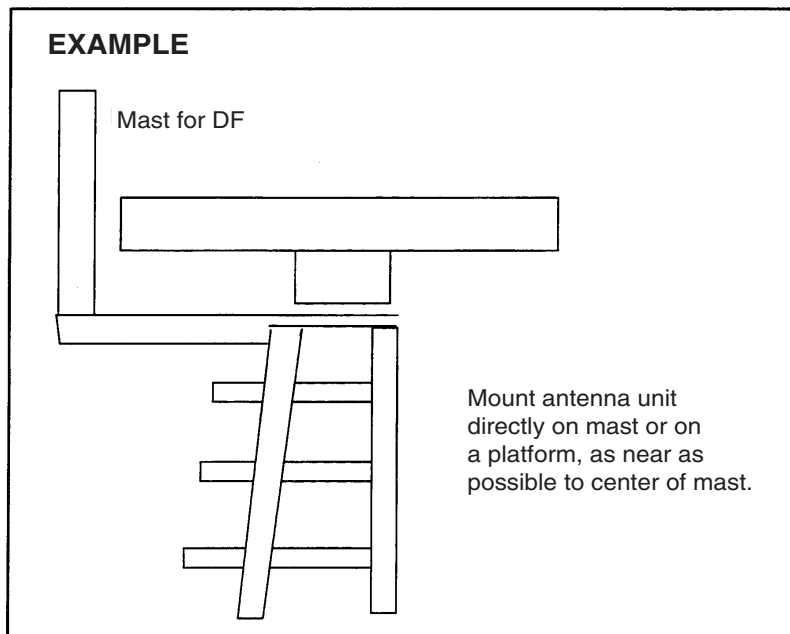
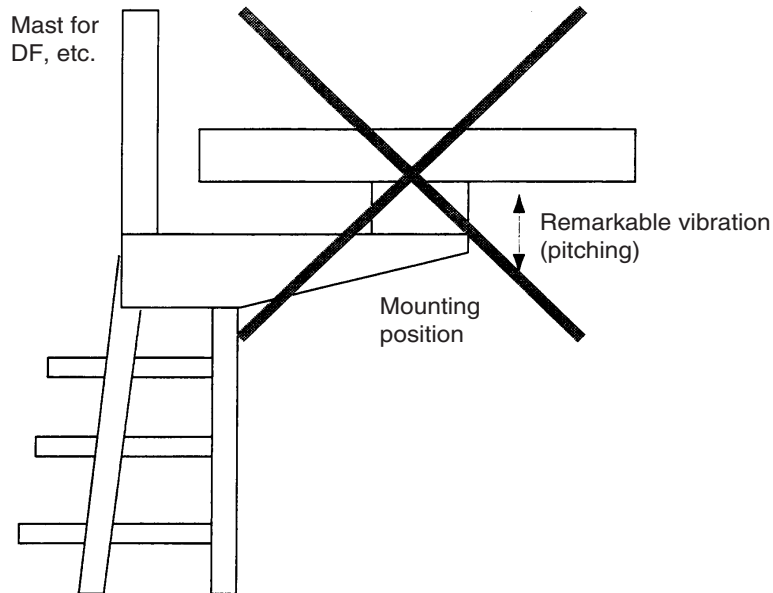

Mounting precaution for S-band antenna unit

Assembling the antenna unit

The antenna unit should be assembled before mounting it. Follow the procedure below to assemble the antenna unit.

1. Screw the guide pins (2 pcs.) in the radiator.
2. Remove the protective cap from the choke guide and radiator.
3. Grease the O-ring and set it to the groove on the choke guide.
4. Place the radiator on the radiator bracket. (Radiator direction is shown by the logo on the bracket. If reversely oriented the radiator cannot be set to the bracket.)
5. Loosely fix the radiator to the radiator bracket with hex bolts (M10×25), spring washers and flat washers.
6. Remove the guide pins and tighten the hex bolts.

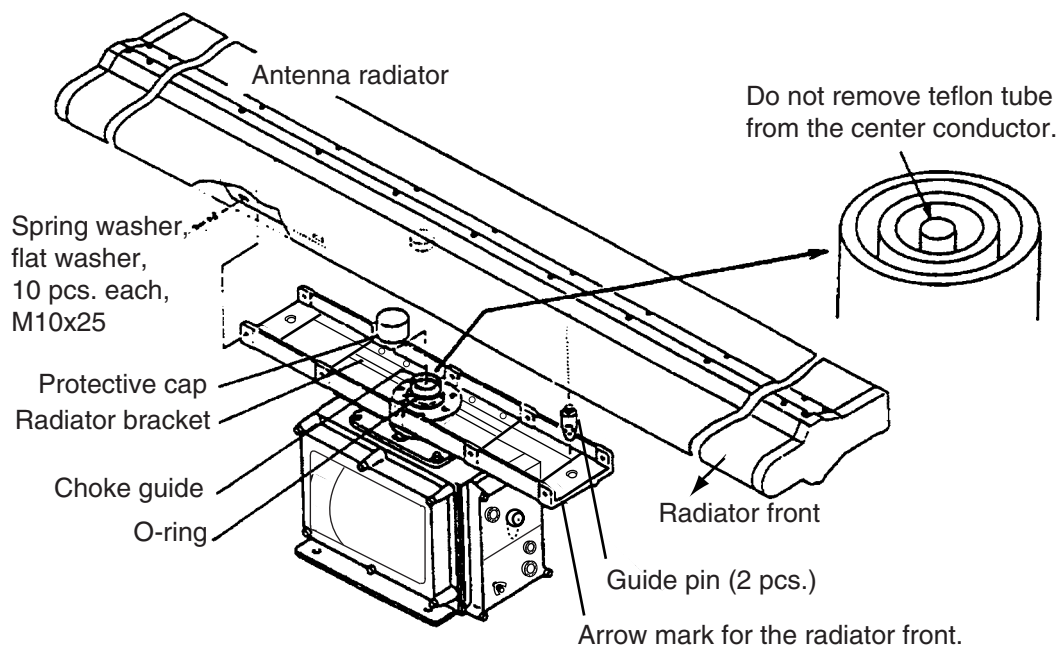

CAUTION

Be sure to remove the guide pins after fixing the radiator.

Injury may result if the guide pins loosen and fall from antenna radar platform.

Assembling the antenna unit

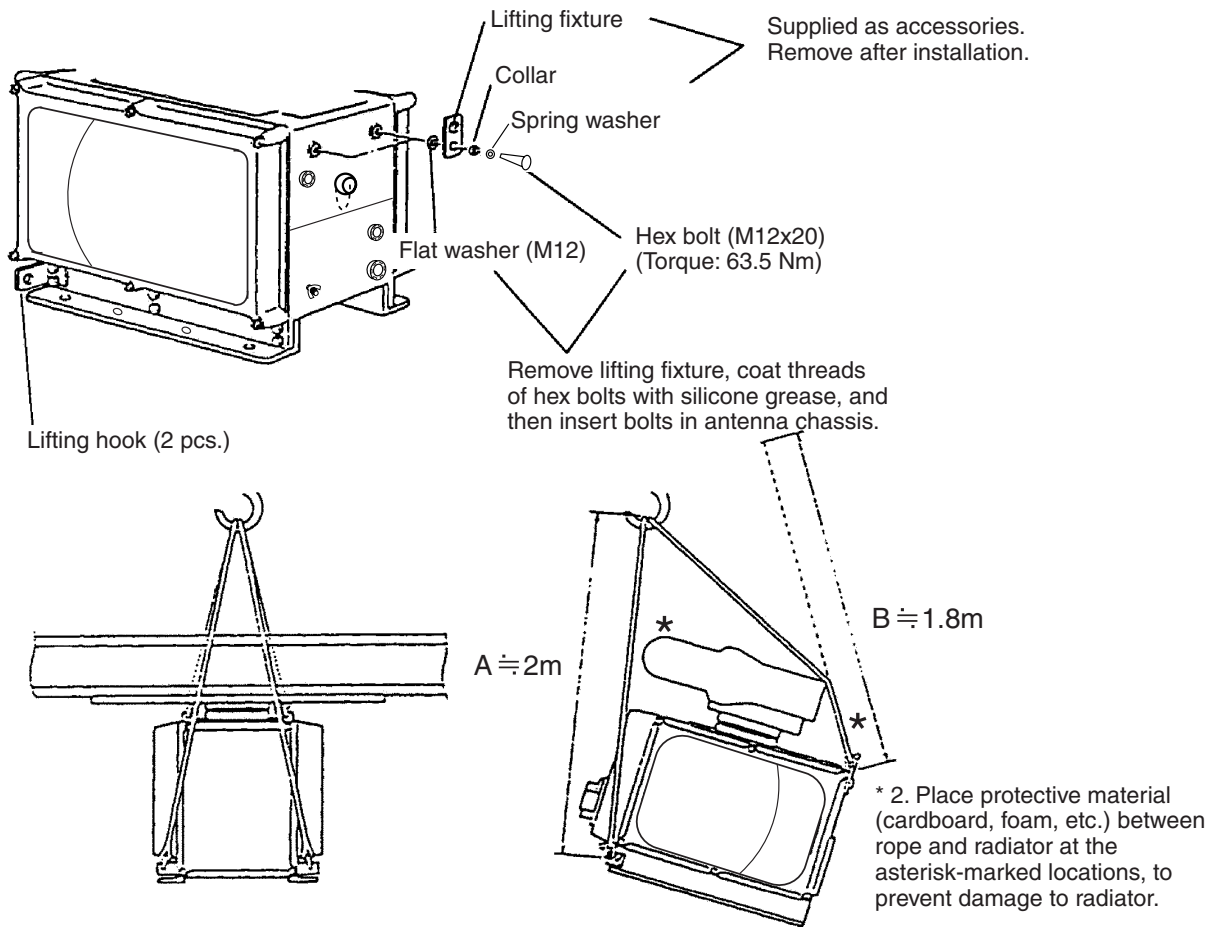

How to hoist the antenna unit

1. Fix the antenna radiator to the antenna unit chassis as shown on page 1-3.
2. Attach the lifting fixtures and collars as shown below.
3. Position the radiator as shown below and arrange the ropes A and B.



Attachment of lifting fixtures, collar and ropes

Fastening the antenna unit to the mounting platform

⚠ WARNING	
	Do not open the equipment unless totally familiar with electrical circuits and service manual. Only qualified personnel should work inside the equipment.
	Wear a hard hat and safety belt when mounting the antenna unit. Serious injury or death can result if someone falls from the radar antenna mast.
	Construct a suitable service platform from which to install the antenna unit. Serious injury or death can result if someone falls from the radar antenna mast.

Note: The antenna is made of cast aluminum, which is subject to electrolytic corrosion if the mounting platform is steel or iron. To prevent electrolytic corrosion, use the supplied seal washers and corrosion-proof rubber mat.

Fix the antenna unit to the mounting location, referring to the procedure below and the illustration on the next page.

1. Referring to the antenna outline drawing, prepare a mounting platform. Drill eight fixing holes of 15 mm in diameter in the mounting platform or the deck.
 - The diameter of the mast for the mounting platform must be over 250 mm.
 - The thickness of the platform must be over 15 mm.
 - The reinforcement rib must be installed diagonally as shown below.

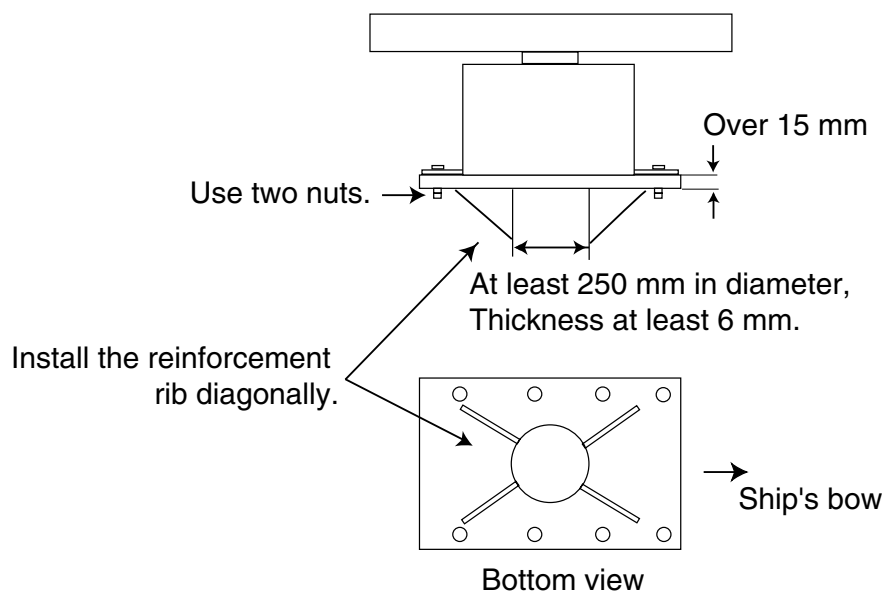

Installation of reinforcement ribs

2. Lay the corrosion-proof rubber mat (supplied) on the mounting platform, aligning the holes on the rubber mat with the fixing holes on the mounting platform.
3. Lay the antenna unit on the rubber mat, orienting it so the cable gland is directed toward ship's bow. Remove the lifting fixtures and collars.
4. Fix the antenna base to the mounting platform with four M12×70 hex bolts, nuts, washers and seal washers (supplied).
5. Arrange the ground point at a location on the mounting platform that is within 300 mm from the ground terminal on the antenna unit. Fasten the ground wire (RW-4747, 340 mm) there, using the M6×25 hex bolt, nut and washers.
6. Connect the other end of the ground wire to the ground terminal on the antenna unit.
7. Coat the ground terminal, ground point on the mounting platform and fixing bolts on the antenna unit with anticorrosive sealant (supplied).

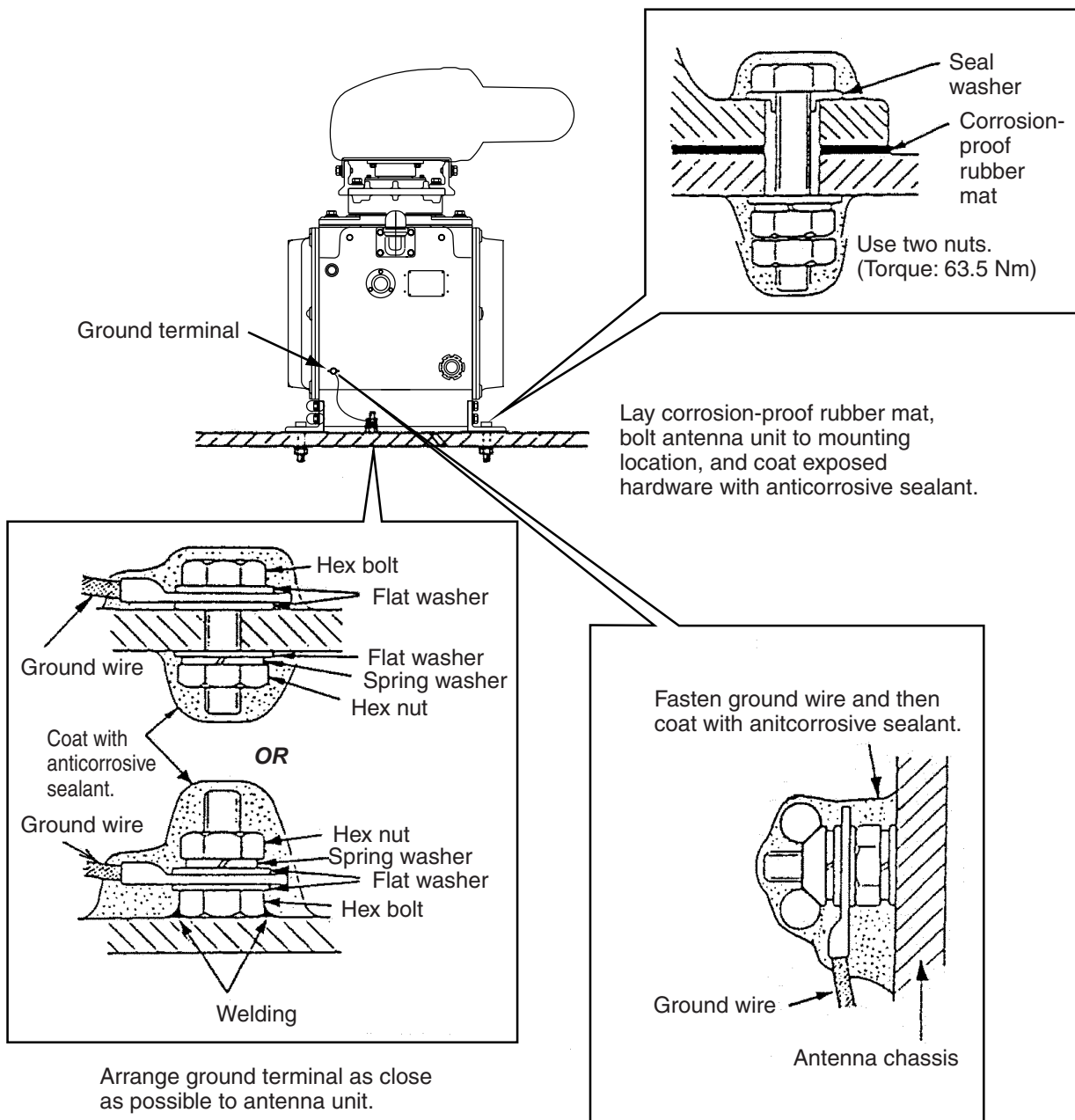

Ground terminal provided on antenna base.

Mounting the antenna unit

1.2 Monitor Unit (for FAR-2167DS)

The monitor unit is can flush mounted in a panel or mounted on a desktop (requires optional accessories).

The FAR-2167DS-BB is not equipped with a monitor unit. Procure a suitable monitor unit locally. Recommended monitor: SXGA (1280×1024), aspect ratio 5:4.

Mounting considerations

When selecting a mounting location, keep in mind the following points:

- Select a location where the screen can be viewed conveniently while facing the bow.
- Locate the unit out of direct sunlight and away from heat sources because of heat that can build up inside the cabinet.
- Locate the unit away from places subject to water splash and rain.
- Leave sufficient space on the sides and rear of the unit to facilitate maintenance, referring to the outline drawing for maintenance space.
- The monitor unit will give interference to a magnetic compass if it is placed too close to the compass. Observe the compass safe distances on page ii to prevent interference to the compass.

Mounting procedure

Flush mounting

Follow the procedure below to mount the monitor unit in a console.

1. Make a cutout in the mounting location referring to the outline drawing shown below.
2. Set the monitor unit to the hole and fix it with four self-tapping screws (6×30).
3. Attach panel hooks near the fixing holes (upper part). See next page. These are used to pull out the monitor unit from the panel for servicing.
4. Attach four panel covers to the fixing holes.

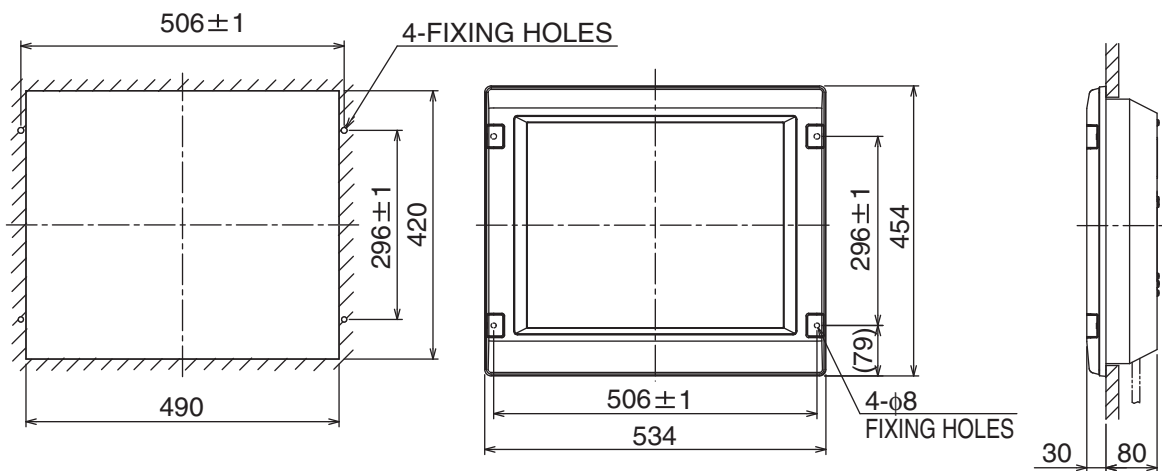

Mounting dimensions for flush mounting the monitor unit

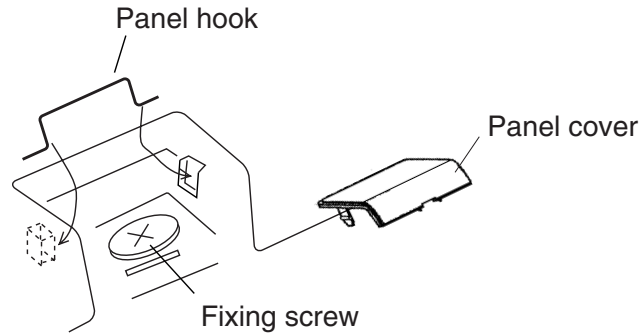

How to attach panel hook and panel cover

Note: If you need to remove the monitor unit from the console, remove the four panel covers with your fingernail and use two panel hooks supplied as accessories to lift the monitor unit.

Desktop mounting

Use the optional desktop mounting kit (Type: FP03-09820, Code No.: 008-535-560) to mount the monitor unit on a desktop.

Contents of desktop mounting kit FP03-09820

Name	Type	Code No.	Qty
Hanger L	03-163-1111	100-305-141	1
Hanger R	03-163-1112	100-305-181	1
Hanger stay	03-163-1113	100-305-191	1
Hole plug	CP-30-HP-13	000-147-143	2
Snap button	KB-13, Black	000-570-276-10	4
Hex. bolt	M6×25	000-802-771	4
Hex. bolt	M10×30	000-802-182	2
Spring washer	M10	000-864-261	2
Flat washer	M10	000-864-131	2

1. Assemble two hangers and hanger stay with two hex bolts (M10×30), flat washers and spring washers and cover each hex bolt with hole plug.
2. Fix the above assembly to the mounting location with four hex bolts (M12, dockyard supply).
3. Fasten the monitor unit to the mounting hanger assembly with four hex bolts (M6×25, supplied).
4. Cover each hex bolt with a panel cover (4 pcs.).
5. Cover fixing holes for hand grips with snap buttons (4 pcs).

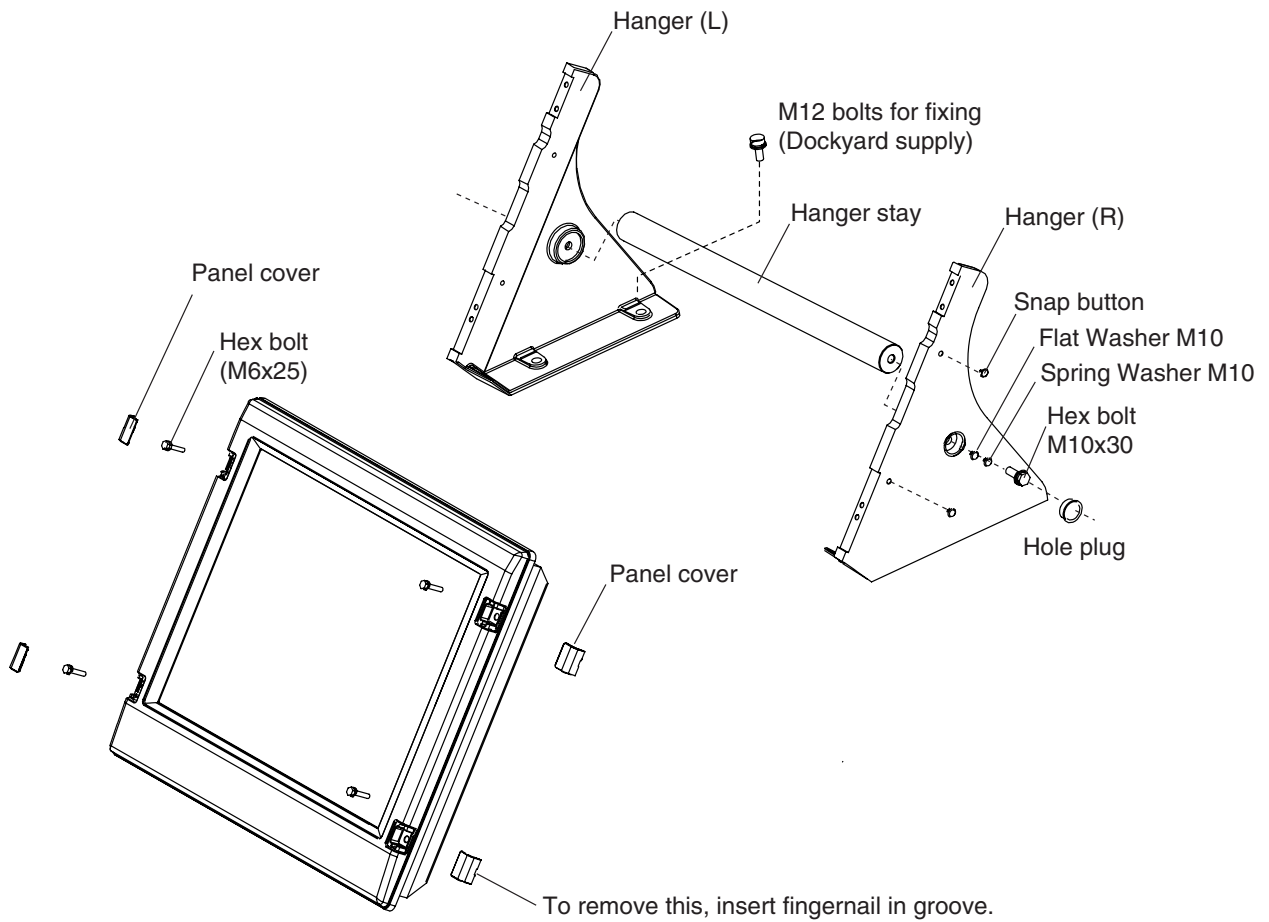

Fastening monitor unit to hanger

Attaching hand grips

Hand grips are optionally available for the desktop-mount monitor unit. Attach them as follows:

1. Remove the snap buttons attached at step 5 on the previous page.
2. Fix hand grips with wave washers, rosette washers and flat head screws.

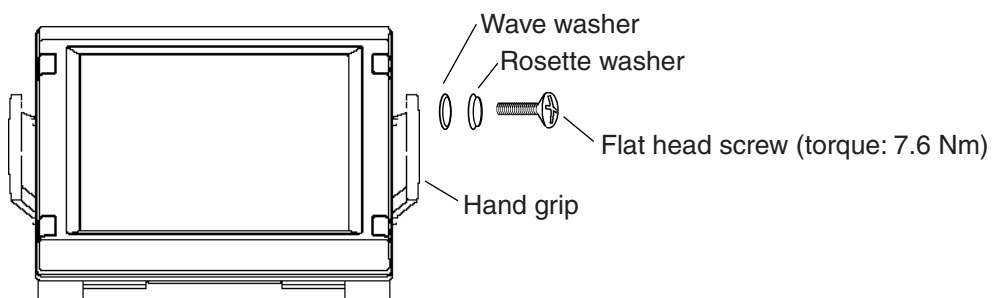

How to attach hand grips

1.3 Control Unit

Mounting considerations

The control unit may be mounted on a desktop, with or without the KB fixing metal (supplied) which mounts the control unit at an angle. When selecting a mounting location, keep in mind the following points:

- Select a location where the control unit can be operated conveniently while observing the display screen.
- Locate the unit away from heat sources because of heat that can build up inside the cabinet.
- Locate the equipment away from places subject to water splash and rain.
- Determine the mounting location considering the length of the signal cable between the control unit and the processor unit. (A 10 m signal cable is attached to the control unit.)
- A magnetic compass will be affected if the control unit is placed too close to it. Observe the compass safe distances on page ii to prevent interference to a magnetic compass.

Mounting procedure

Fixing with KB (keyboard) fixing plate

The KB fixing plate sits the control unit at a comfortable angle, like the retractable legs on a PC keyboard.

1. Fix the KB fixing plate to the bottom of the control unit.
2. Attach cushions (three for RCU-014, two for RCU-015/RCU-016) to the bottom of the control unit as shown below.
3. Fix the unit to a desired location with self-tapping screws (local supply).

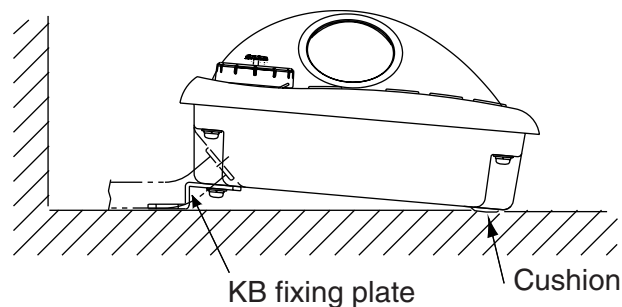

Control unit RCU-014/015/016, side view

Fixing without KB fixing plate

1. Drill four mounting holes of 5 mm diameter, referring to the outline drawing at the back of this manual.
2. Fix the control unit with four screws (M4) from the under side of the desktop. (M4 screws with a sufficient length for the thickness of the desktop should be provided locally.)

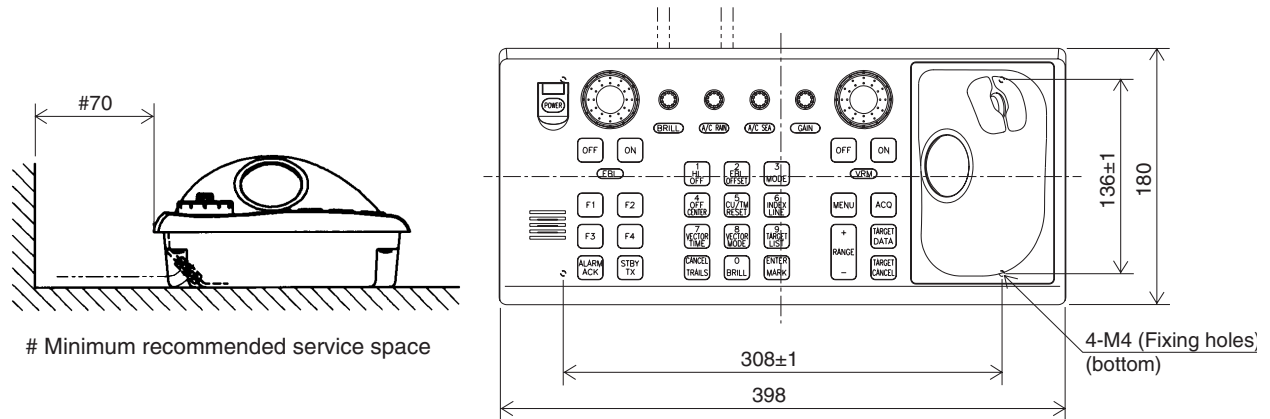

Mounting dimensions for control unit RCU-014

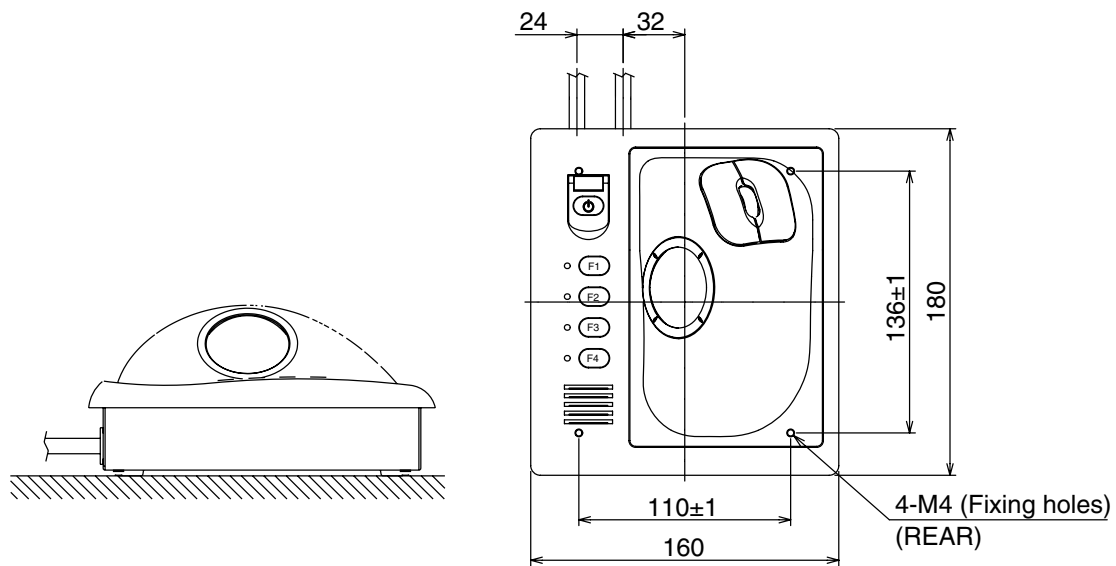

Mounting dimensions for control unit RCU-015/RCU-016

Flush mounting

Use the optional flush mount kit FP03-09870 (Code No. 008-535-630) to flush mount the control unit RCU-014, RCU-015 and/or RCU016 in a console.

Contents of flush mount kit for RCU-014/015/016

Name	Type	Qty
Mounting plate	03-163-7531	4
Hex bolt	M5	4
Wing screw	M5×40	4
Pan head screw	M4×12	4

1. Prepare a cutout in the mounting location as shown in the figure below.

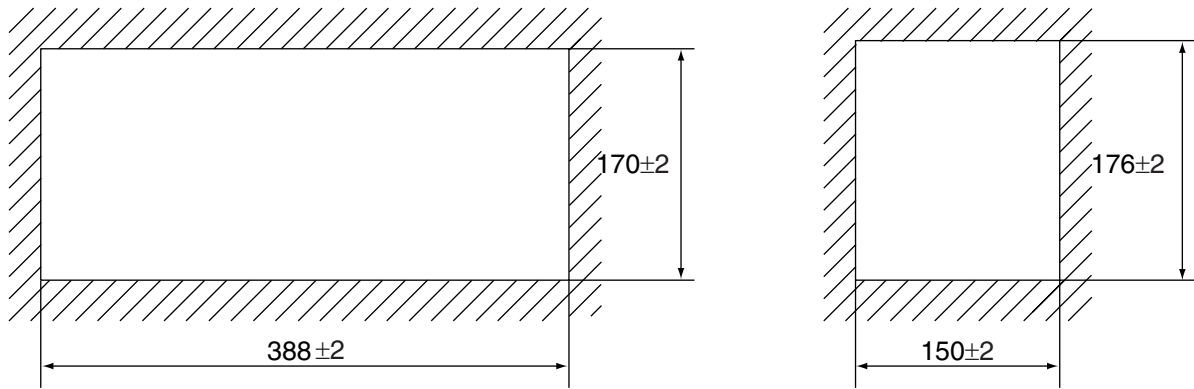

Flush mount cutout for RCU-014

Flush mount cutout for RCU-015 and RCU-016

2. Set the control unit to the cutout.
3. From the rear side, attach the mounting plate to the control unit with four screws.
4. Screw the wing screw to each mounting plate and then insert hex bolt to each wing screw.
5. Fasten each wing screw and then fasten the hex nuts as shown in the figure below.

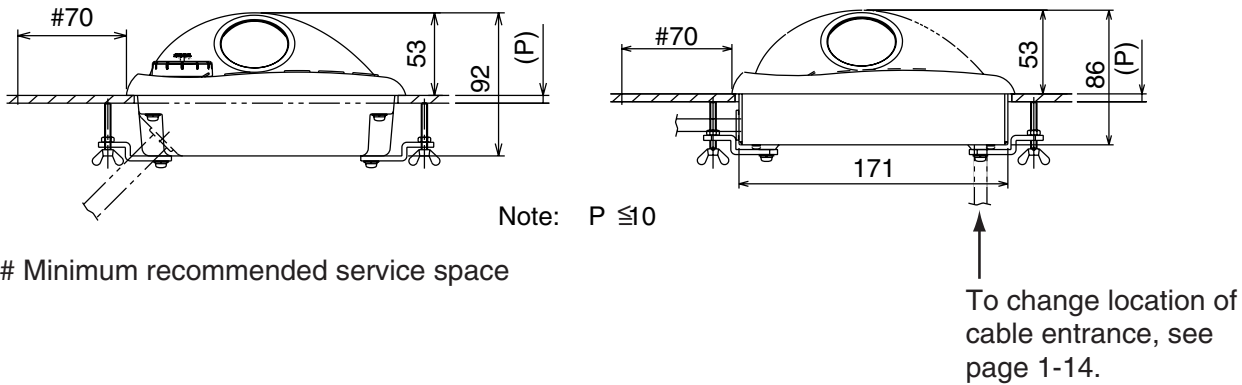

Note: $P \leq 10$

Minimum recommended service space

To change location of cable entrance, see page 1-14.

Flush mount mounting dimensions for control unit RCU-014 (left) and RCU-015/RCU-016

Connecting RCU-016 in series with RCU-014

1. Pass the cable from RCU-016.

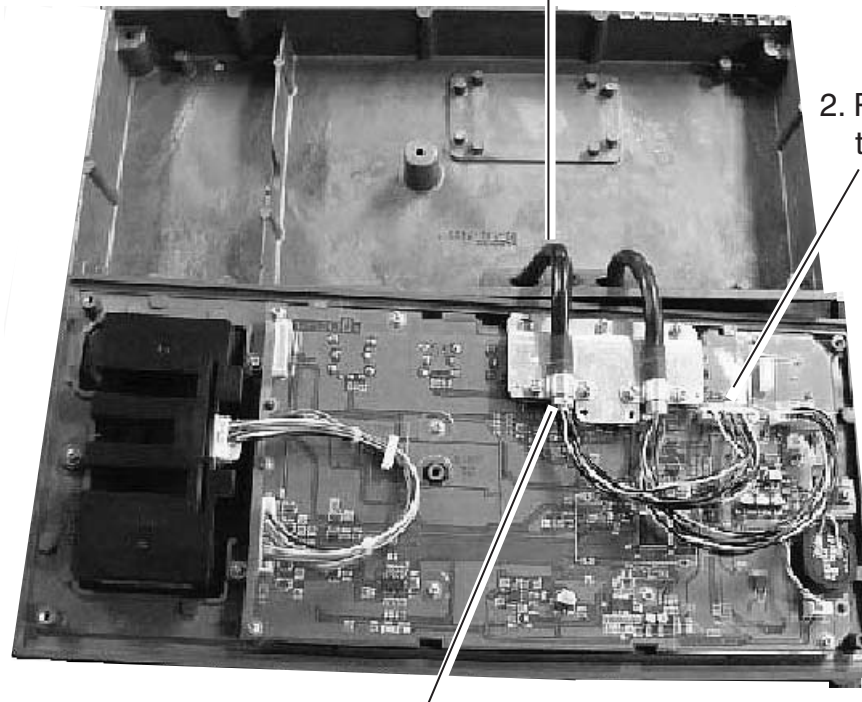

2. Plug in connector to J502.

3. Clamp the copper part of the cable with the cable clamp.

Control unit RCU-014, inside view

Changing the cable entrance on control unit RCU-015/RCU-016

To change the cable entrance from the side (default) to the bottom, modify the unit as shown below.

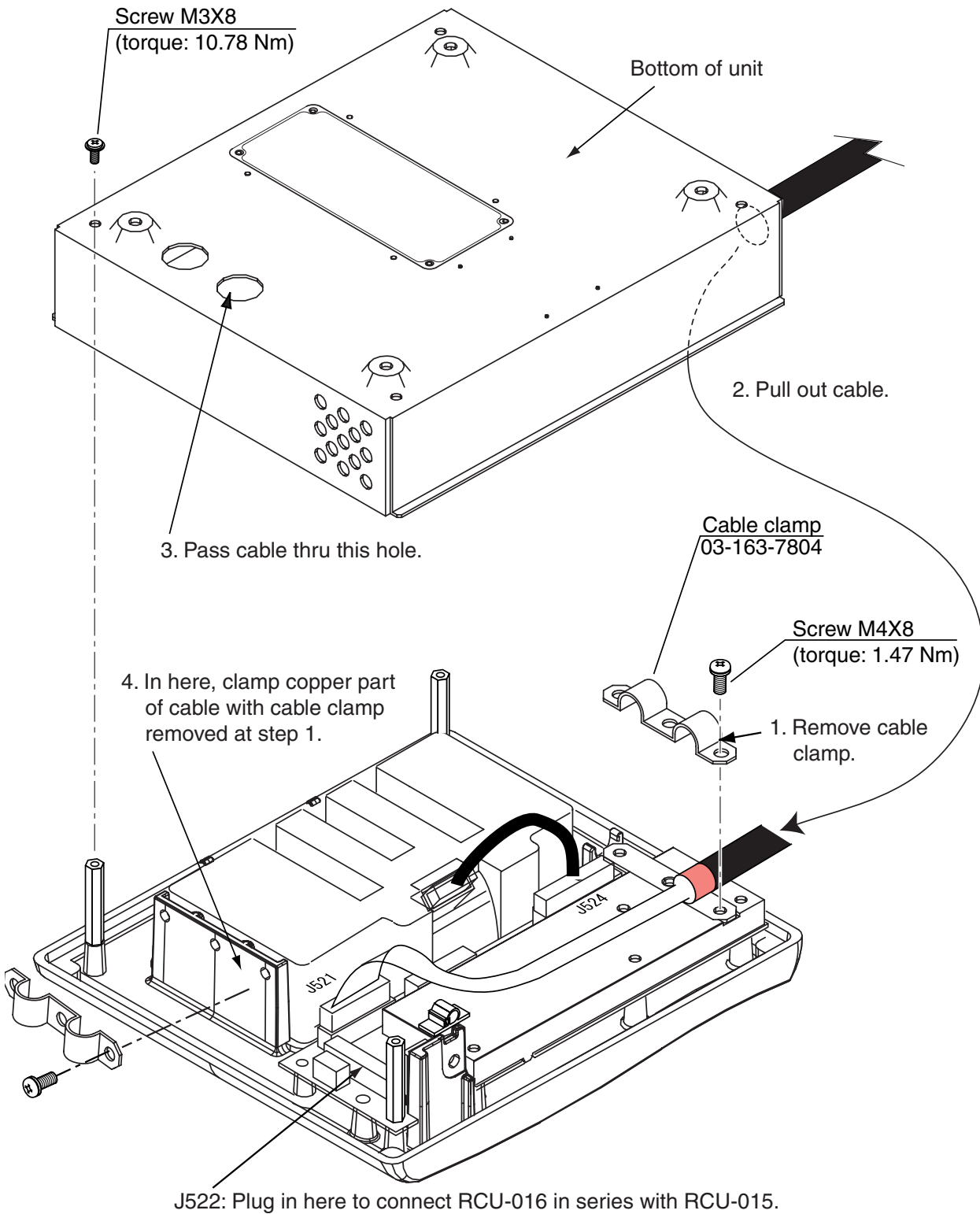

Changing cable entrance on control unit RCU-015/RCU-016

1.4 Processor Unit

Mounting considerations

When selecting a mounting location, keep in mind the following points:

- Locate the processor unit away from heat sources because of heat that can build up inside the cabinet.
- Locate the unit away from places subject to water splash and rain.
- Leave sufficient space at the sides and rear of the unit to facilitate maintenance, referring to the outline drawing.
- A magnetic compass will be affected if the processor unit is placed too close to it. Observe the compass safe distances on page ii to prevent interference to a magnetic compass.

Mounting procedure

Fix the unit with four M6 bolts or self-tapping screws.

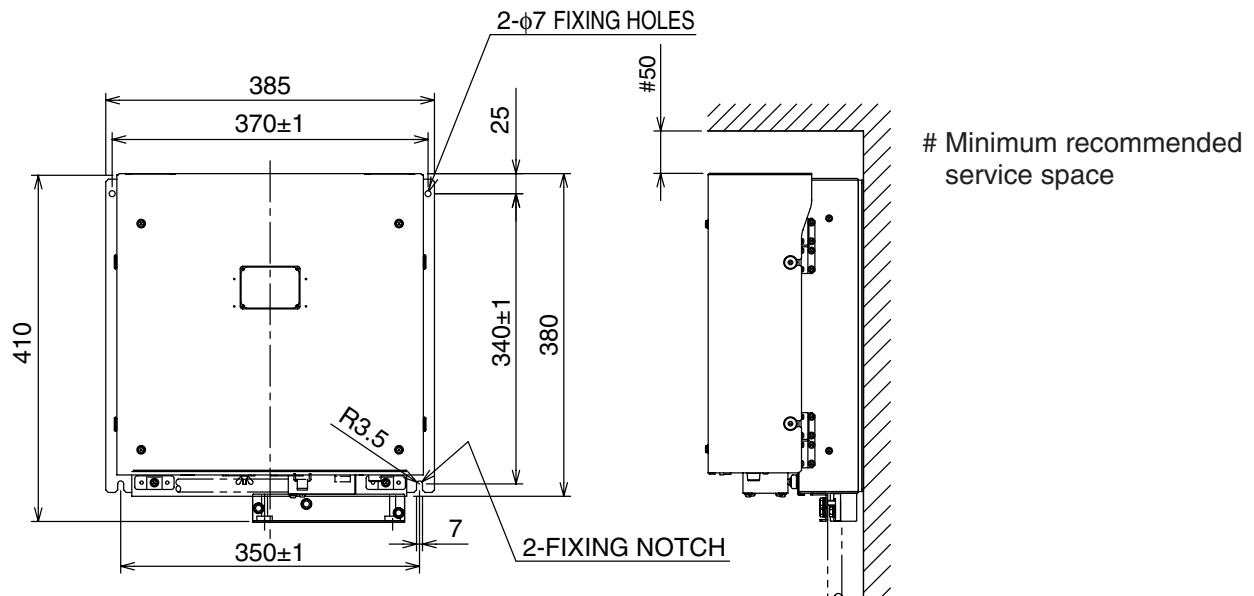

Mounting dimensions for processor unit

Note: If you fix the unit with the cable entry up, do not unfasten the screw (M3x10) that fastens the upper case assy. and lower case assy. of the processor unit.

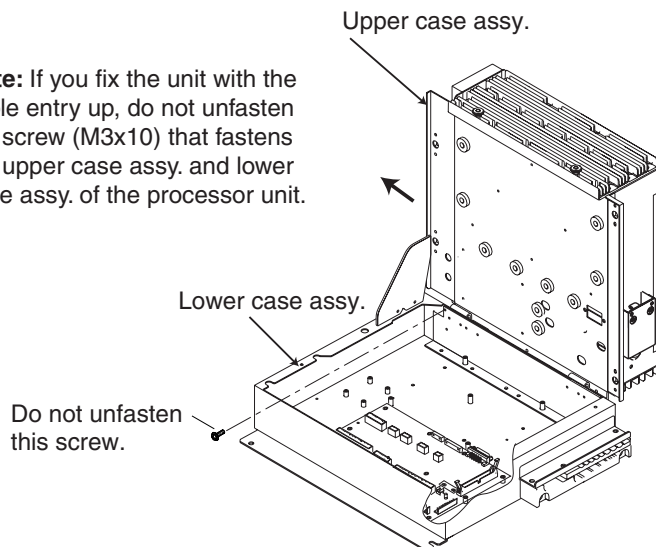

1.5 Power Supply Unit

Mounting considerations

The power supply unit may be mounted on a bulkhead or a deck. Because it has no operation requirements it can be located almost anywhere, provided the location is well ventilated.

Mounting procedure

Fix the unit to the mounting location with four 6×20 self-tapping screws (local supply). For mounting on a bulkhead, do the following:

1. Mark location for mounting holes.
2. Screw in the self-tapping screws at the location for the bottom fixing holes, leaving a gap of about 5 mm between the bottom of the screw head and bulkhead.
3. Set the unit to the screws inserted at step 1.
4. Fasten the self-tapping screws at the top of the unit.
5. Tighten all self-tapping screws.

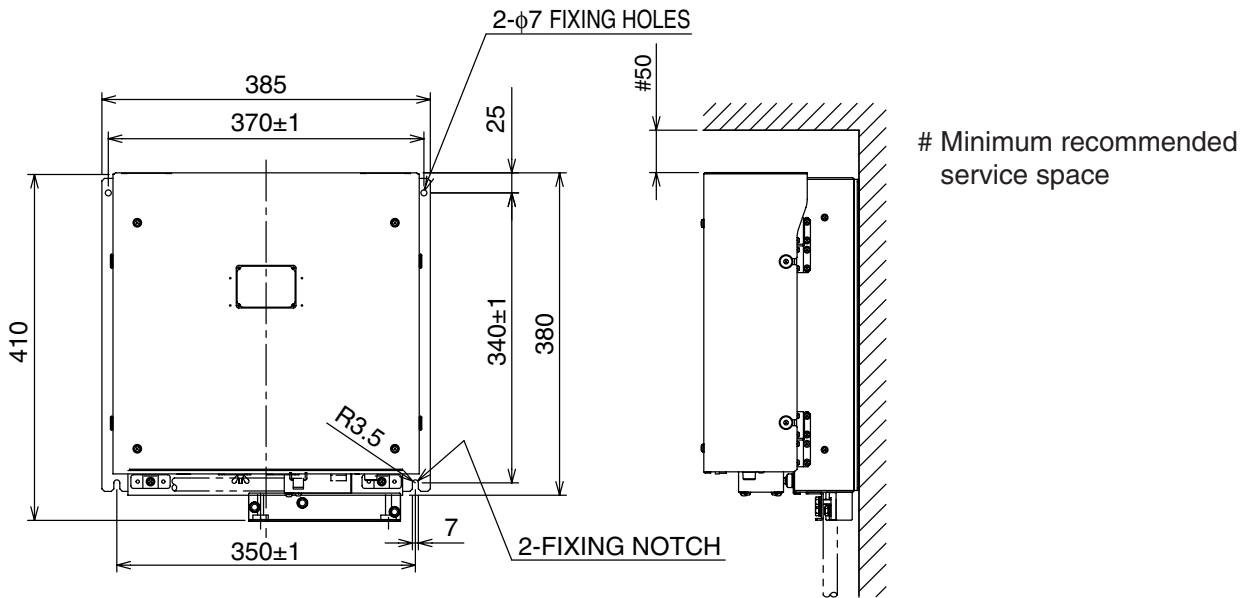

Mounting dimensions for power supply unit

2. WIRING

2.1 Wiring Overview

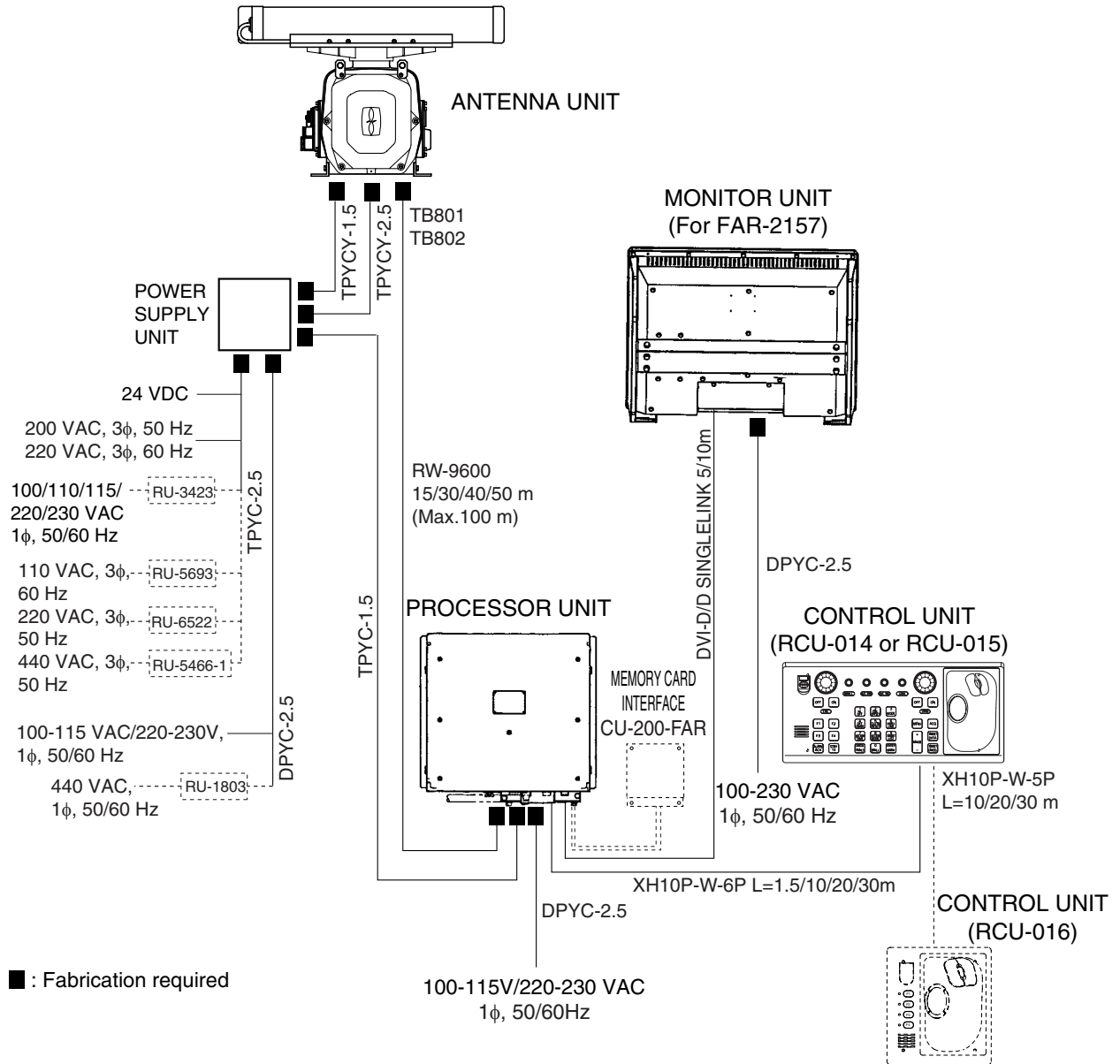

2.2 Antenna Unit

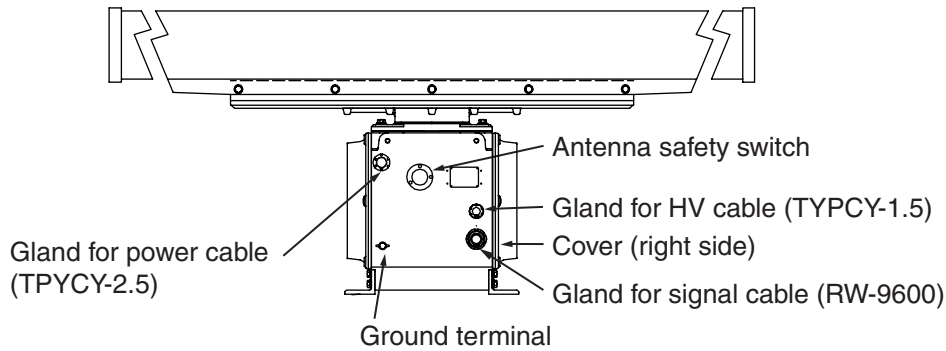

Antenna unit, front view

Fabricating signal cable RW-9600 and HV cable TYP CY-1.5

1. Use a ratchet or box wrench (diagonal 13 mm) to open port- and starboard-side covers on the antenna unit.
2. Unfasten the gland nut for the signal cable and remove the gasket, flat washers (3 pcs.) and gland cap. (The gland cap may be discarded.)
3. Fabricate the signal cable as follows:
 - a) Remove the vinyl sheath, armor and sheath by the amounts shown in the figure below.
 - b) Unravel the shield to expose cores.
 - c) Shorten cores (except coax) considering their locations on the terminal inside the antenna unit.
 - d) Shorten the shield, leaving 210 mm. Attach crimp-on-lug (FV5.5-4, yellow, $\phi 4$) to shield.
 - e) Remove the sheath of cores by 6 mm.
 - f) Unravel armor.
 - g) Fix vinyl wire, coaxial cable and shield by taping the shield with vinyl tape at the location shown below.

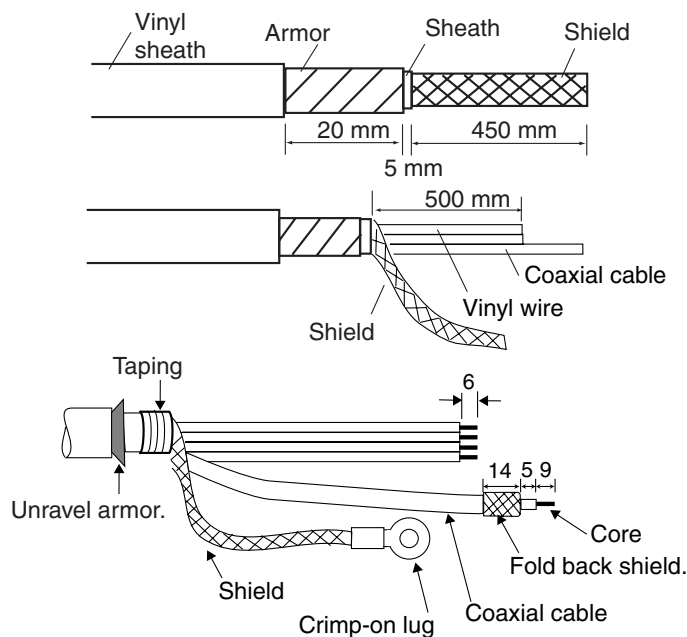

Fabricating signal cable RW-9600

- In the order shown in the figure below, pass the gland nut, flat washers (3 pcs.) and gasket onto the signal cable.

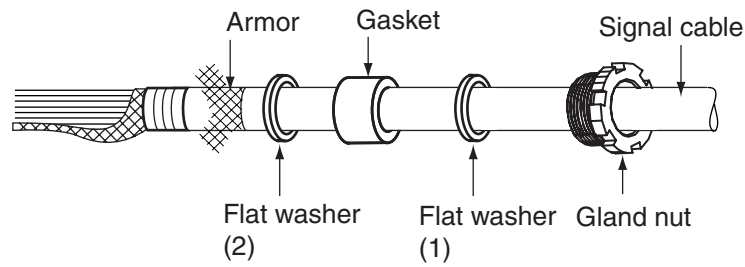

- As shown in the figure below, fold back the armor onto flat washer (2) and insert remaining armor through flat washer (3). Cut off the part of the armor that protrudes past the flat washers (2) and (3).

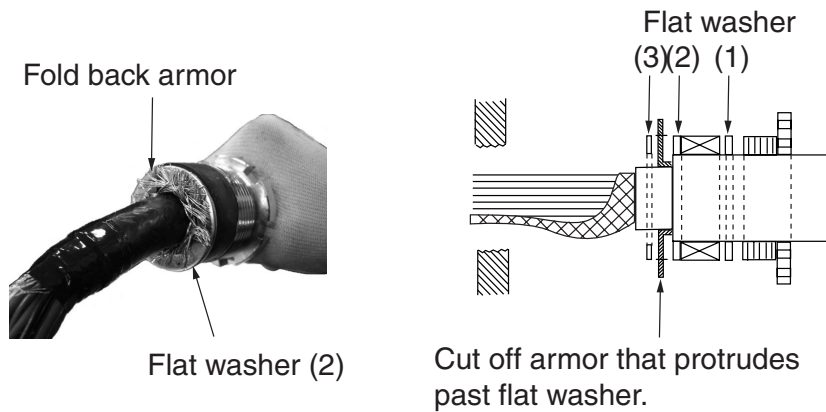

- Lead the signal cable through its cable gland and then into the chassis. Coat the threaded part of gland nut with sealant (supplied) and then tighten the nut.

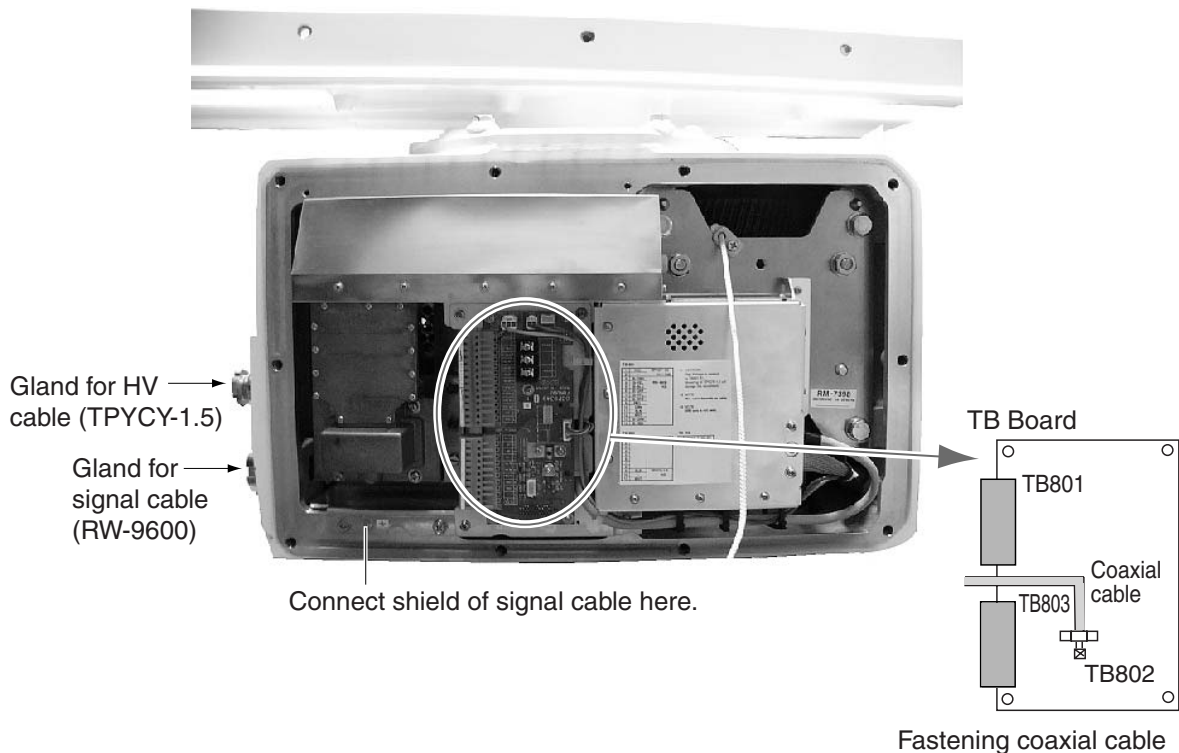

Antenna unit, front view

7. Using the terminal opener provided, connect cores (except coaxial cable) to their appropriate locations on TB801 on the TB Board. Refer to the interconnection diagram for wiring details.
8. Connect the coaxial cable to TB802, referring to the right-hand illustration below..

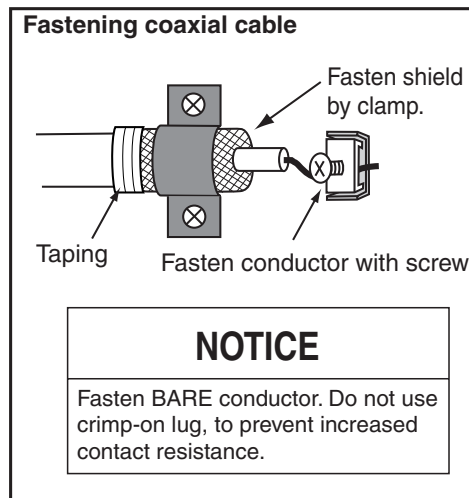
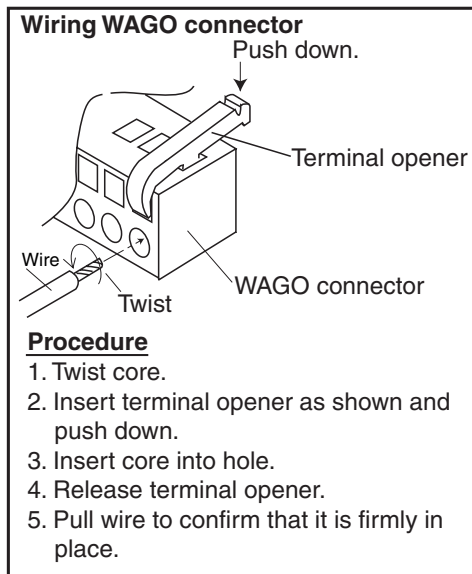

How to wire WAGO connector

9. Attach crimp-on lug (FV5.5-4) to the shield of the signal cable and fasten it with the screw at the location specified in the illustration on the preceding page.
10. Process unused cores as follows:
 - a) Slip shrink tubing onto cores and heat.
 - b) Bind unused cores with cable tie.
11. Unfasten the gland nut for the HV cable and remove gasket, flat washers (3 pcs.) and gland cap. (The gland cap may be discarded.)
12. Fabricate the HV cable as shown below.

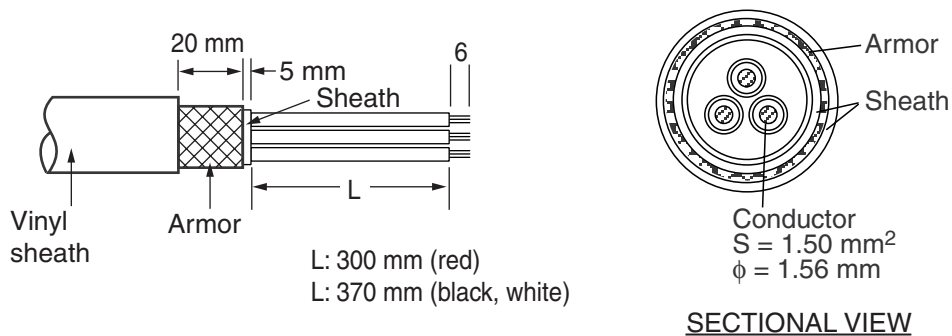

How to fabricate HV cable TYP CY-1.5

13. In the order shown in the figure below, pass the gland nut, flat washers (3 pcs.) and gasket onto the HV cable.
14. As shown in the figure below, fold back the armor onto the flat washer and insert it thru the other flat washer. Cut off the part of the armor that protrudes past the washer.

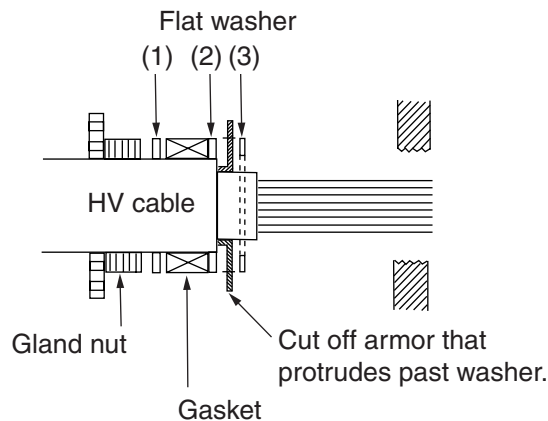

15. Pass the HV cable through its cable gland and tighten gland nut.
16. Using the terminal opener, connect wiring to TB901, referring to the interconnection diagram.



CAUTION

High voltage is present at the No. 6 pin of TB901. Miswiring at this pin can damage the antenna unit.

17. Close the cover.
18. Seal the cable gland for the HV cable with putty.

Fabricating the power cable TYP CY-2.5

1. Use a ratchet or box wrench to open the port-side cover on the antenna unit.
2. Unfasten the gland nut for the power cable and remove gasket, flat washer (3 pcs.) and gland cap. (The gland cap may be discarded.)
3. Fabricate the power cable as shown below. Unravel the armor. Wrap sheath with vinyl tape to fix base of vinyl wire.

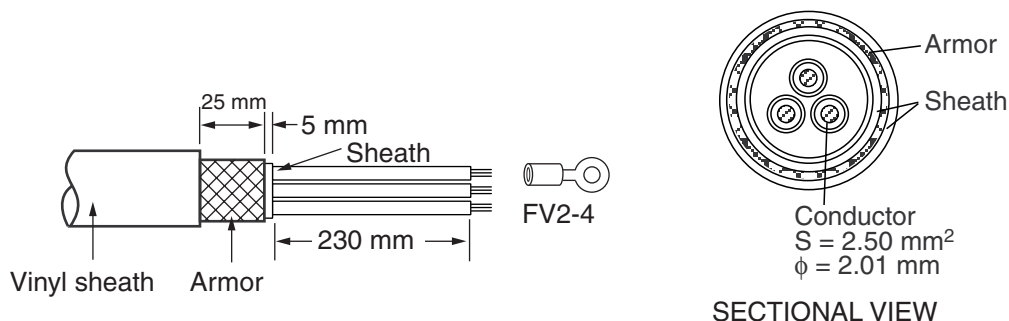

How to fabricate power cable TYP CY-2.5

4. In the order shown in the figure below, pass the gland nut, flat washers (3 pcs.) and gasket onto the power cable.
5. As shown in the figure below, fold back armor onto flat washer and insert it thru the other flat washer. Cut off part of armor that protrudes past flat washer..

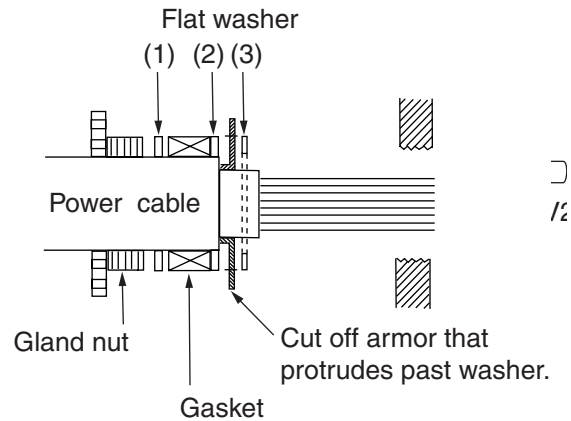

Passing flat washer, etc. onto HV cable

6. Pass the power cable through its cable gland and then tighten the gland nut..
7. Pass the power cable to the rear of the antenna unit.

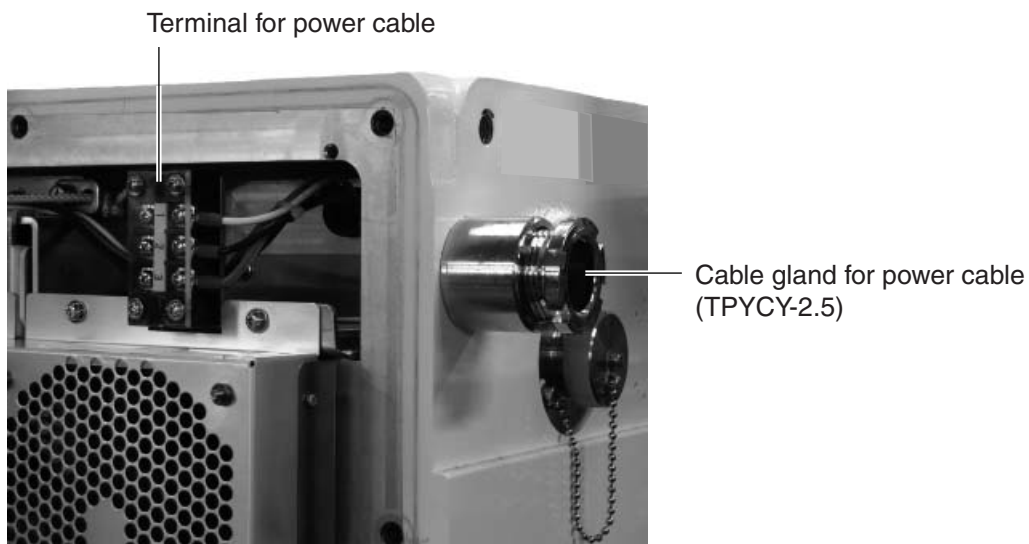

Antenna unit, left-side view

8. Connect the power cable to its terminal, referring to the interconnection diagram.
9. Close the cover.
10. Seal the cable gland for the power cable with putty.

2.3 Monitor Unit (for FAR-2167DS)

Two cables are terminated at the monitor unit: the signal cable from the processor unit (5 m or 10 m cable) and the power cable from the ship's mains. The signal cable comes with a connector pre-attached to it for connection to the monitor unit. Fabricate the power cable as below. Use DPYC-2.5 (Japan Industry Standard) cable or the equivalent. Be sure to ground the unit, with IV-8sq wire (local supply).

Note: Pass the AC line through a double-contact breaker (shipyard supply). Further, for vessels where the power line is grounded, connect one end of the line to the C (common) terminal and the other end to the H terminal.

Fabricating the power cable DPYC-2.5

1. Remove the armor from the cable by 40 mm.
2. Remove the vinyl sheath by 35 mm.
3. Remove the insulation from the cores by about 10 mm.
4. Peel paint from the armor by 40 mm.
5. Cover the end of the armor with vinyl tape. Fix crimp-on lugs (FV5.5-4, yellow) to the cores.

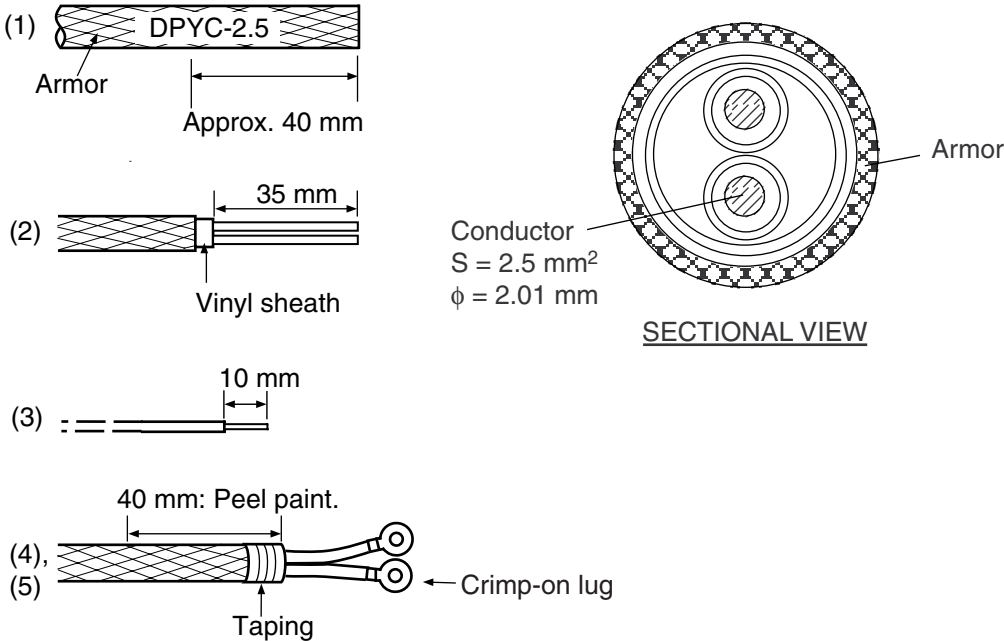

Fabricating power cable DPYC-2.5

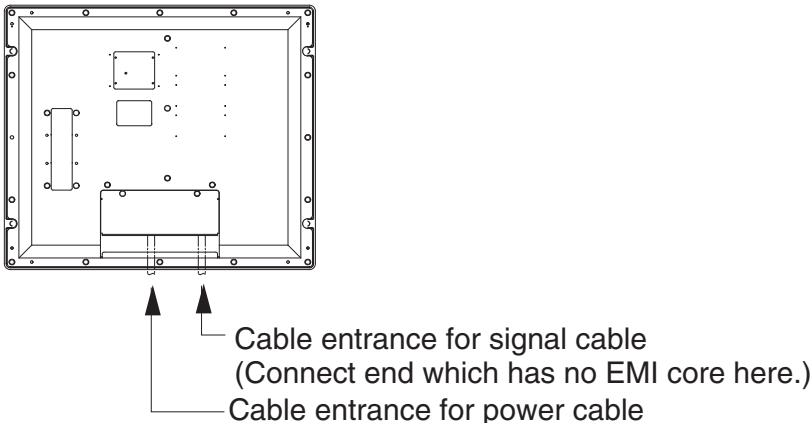

Monitor unit MU-201CR, rear view

2.4 Processor Unit

Four cables are terminated at the processor unit: the antenna unit cable, monitor unit cable (FAR-2167DS only), control unit cable and the power cable. Cables other than the power cable come with a connector preattached to them. Fabricate the power cable as below.

Note: Pass the AC line through a double-contact breaker (shipyard supply). Further, for vessels where the power line is grounded, connect one end of the line to the C (common) terminal and the other end to the H terminal.

Fabricating the power cable DPYC-2.5

1. Remove the armor from the cable by 40 mm.
2. Remove the vinyl sheath by 35 mm.
3. Remove the insulation from the cores by about 10 mm.
4. Peel paint from the armor by 40 mm.
5. Tape the end of the armor with vinyl tape. Fix crimp-on lugs (FV5.5-4, yellow, supplied) to the cores.

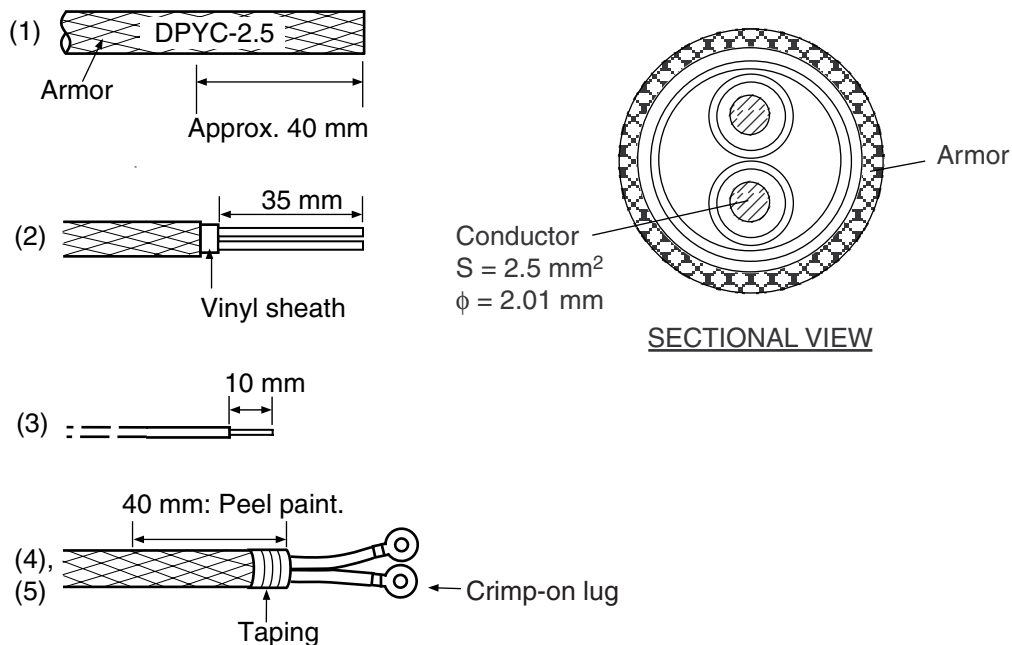

Fabricating power cable DPYC-2.5

Connection of cables

The power cable is connected to the terminal board on the rear panel and the signal cable from the monitor unit is connected to the DVI-D connector. Other cables are connected to the printed circuit board 03P9342. Be sure to ground the unit, with IV-8sq wire (local supply).

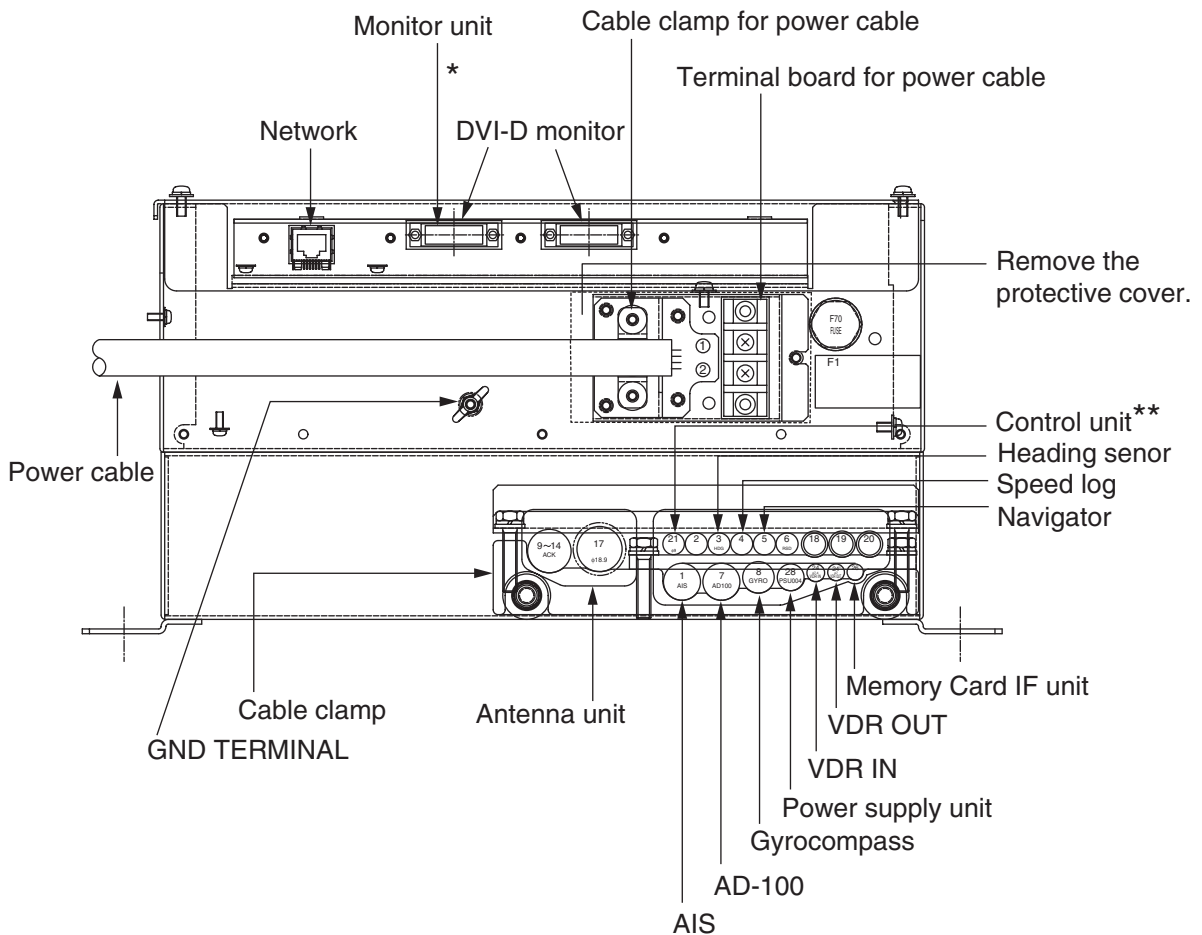

Processor unit, rear view

*: The connector with EMI core should be connected to the processor unit.

** : The configuration of optional cable between the processor unit and the control unit is as follows. Note that the cable fabrication for each end is different.

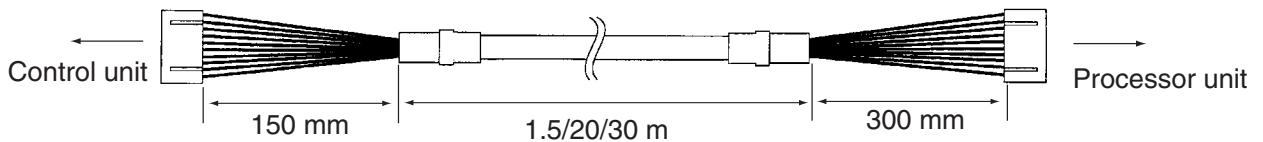

Cable XH10P-W-6P L=20/30M

When the RCU-016 is installed, optional cable (XH10P-W-5P-A, L=10/20/30M) is required. Cable fabrication for each end is the same.

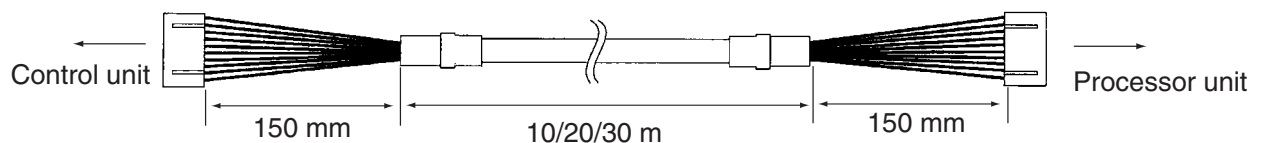

Cable XH10P-W-5P-A L=10/20/30M

Location of connectors

Open the processor unit as shown below to access the 03P9342 board, which is for connection of external equipment.

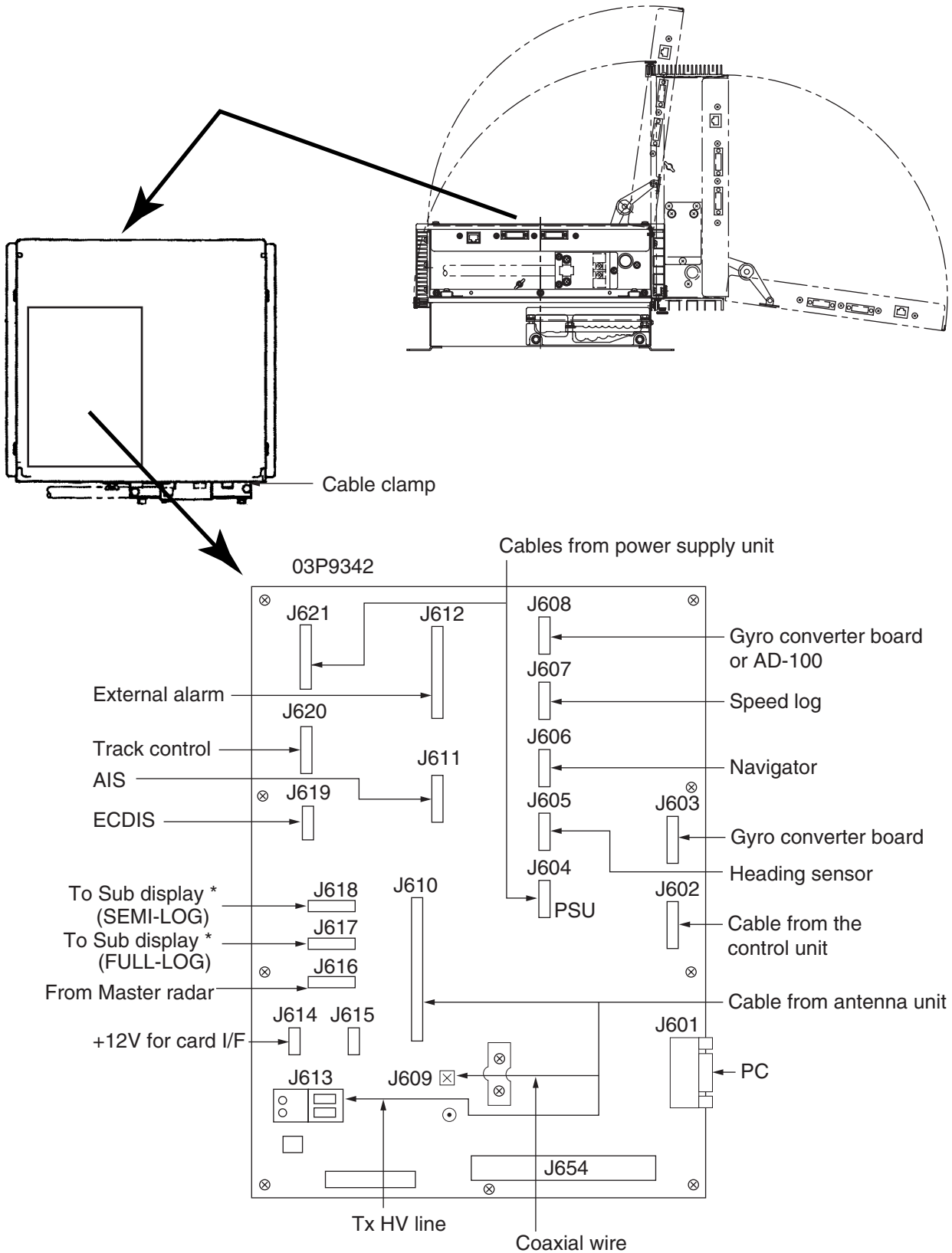

Location of connectors inside the processor unit

*: See page 2-11 for details.

Cable fabrication for the cables connected to the 03P9342 board

Signal cable RW-9600 (Between antenna unit and processor unit)

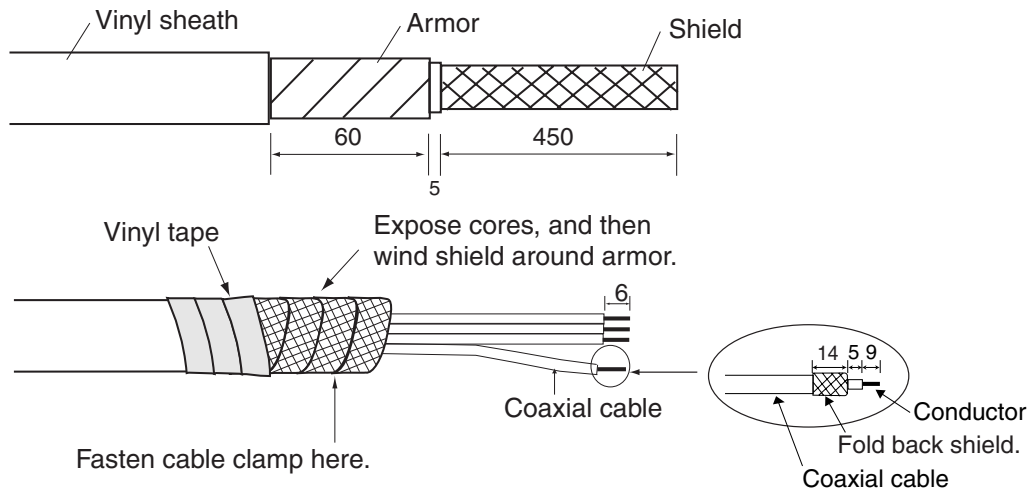

Power cable TPYC-1.5

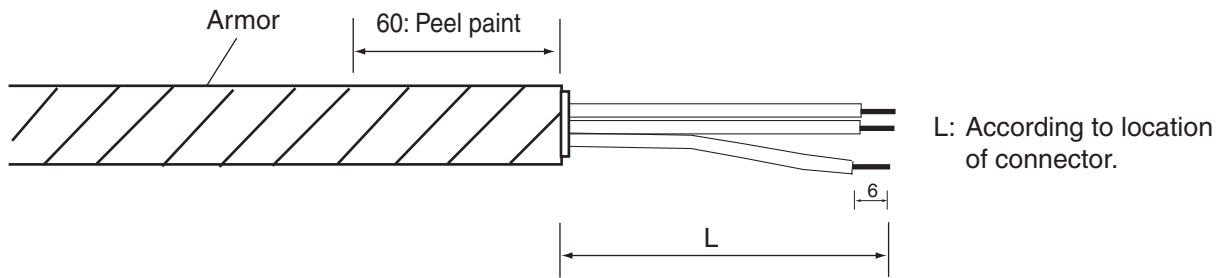

Cables for optional equipment (use TTYCS-1 or TTYCS-4, or equivalent)

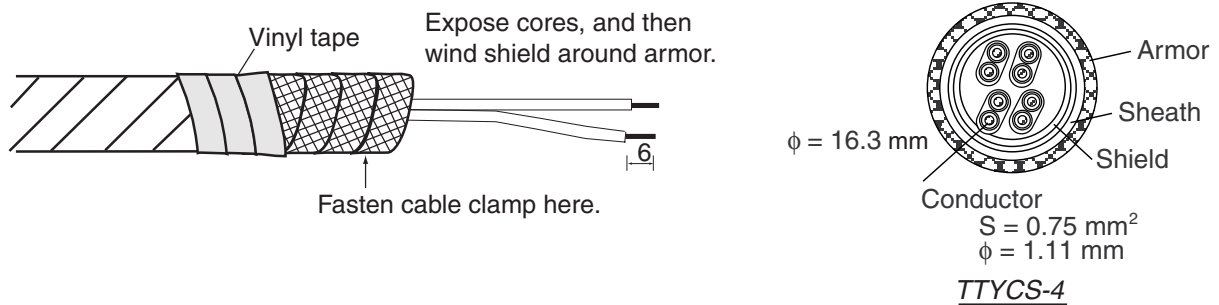
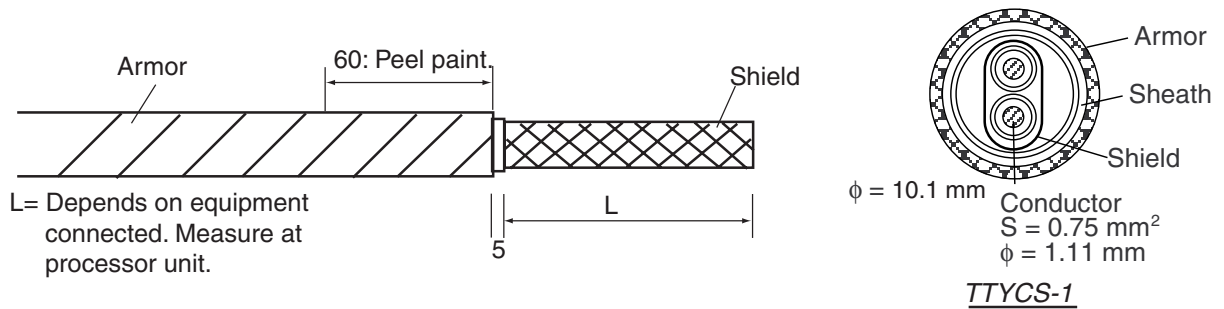

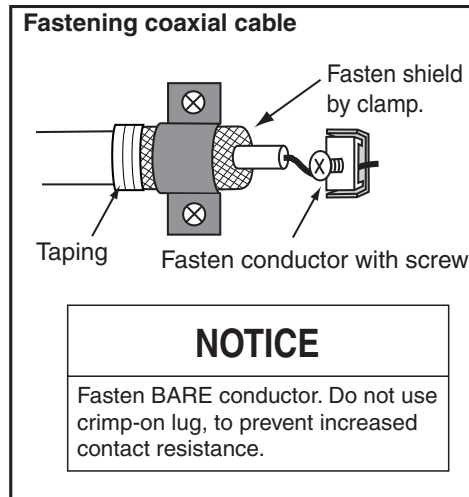
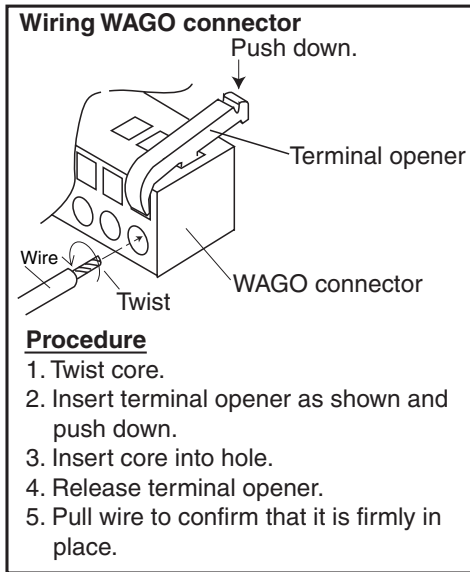

Connection of Sub-display

A conventional remote display and/or FAR-2xx7 series radar can be connected to J617 (FULL-LOG) and J618 (SEMI-LOG) in the processor unit as a sub-display. However, the control for GAIN and STC are different depending on J617 and J618. Refer to the table to connect sub-displays.

Port		Conventional remote display	FAR-2167DS
J617(FULL-LOG)GAIN and STC are not controlled. Video signal for conventional sub display is output.	Overall gain	Even if input video level is adjusted to 4 Vp-p, the gain is 8 db lower than that on the master radar.	The gain is 8 dB lower than that on the master radar.
	GAIN control	The GAIN control is effective.	The GAIN control has no effect.
	STC control	The STC control is effective.	The STC control has no effect.
J618(SEMI-LOG)Video signal of main radar controlled GAIN and STC is output.	Overall gain	When input video level is adjusted to 4 Vp-p, the gain becomes the same as that on the master radar.	The gain is almost same as that on the master radar.
	GAIN control	The GAIN control is effective.	The GAIN control has no effect.
	STC control	The STC control changes the radar image, however STC is doubly applied, resulting in improper radar picture. Therefore, it is not recommended to use this port.	The STC control has no effect.

2.5 Power Supply Unit

Wire the power supply unit referring to the interconnection diagram. Be sure to ground the unit, with IV-8sq wire (local supply).

Note: Pass the AC line through a double-contact breaker (shipyard supply). Further, for vessels where the power line is grounded, connect one end of the line to the C (common) terminal and the other end to the H terminal.

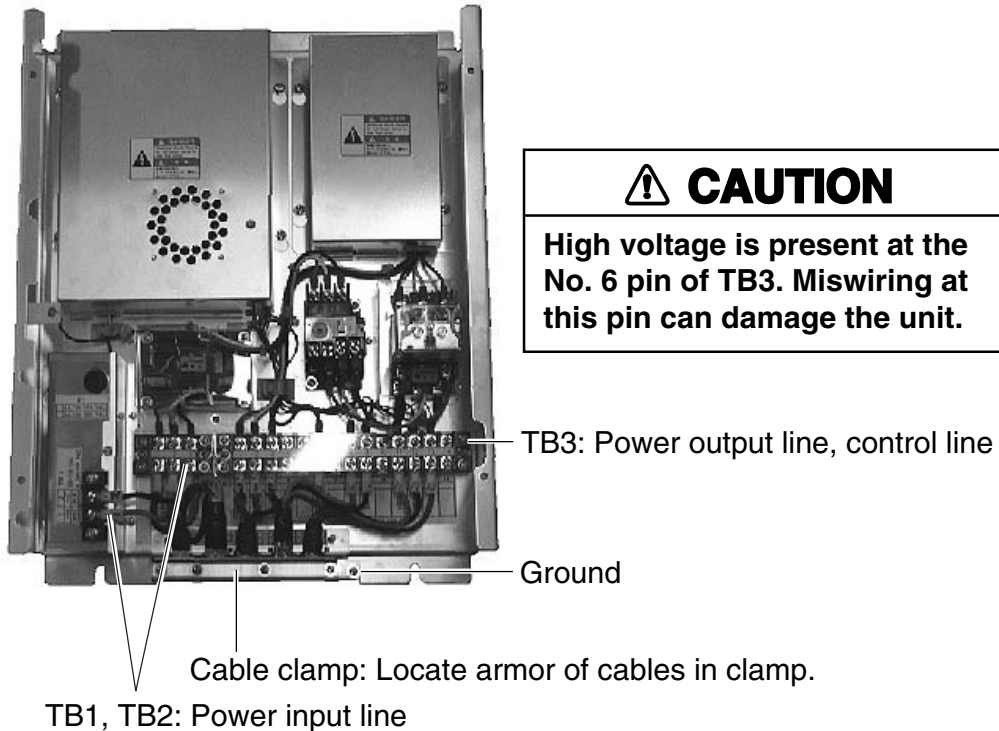

Power supply unit, inside view

Fabricating cable connected to terminal TB1, TB2, TB3

Terminal TB1: cable DPYC-2.5

See page 2-8 for sectional view of cable if using equivalent cable.

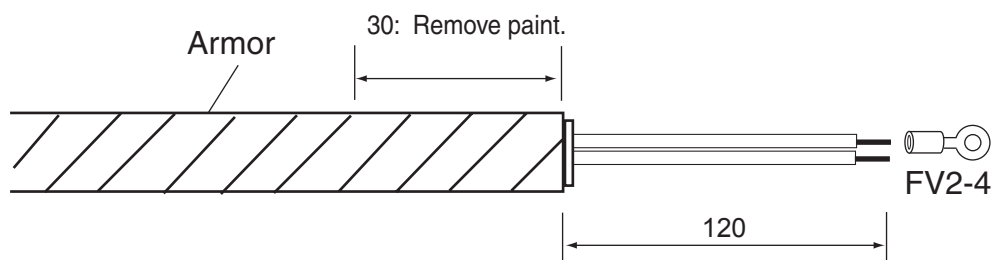

Terminal TB2: cable TPYC-2.5 (for antenna motor)

Terminal TB3: #11-#13, cable TYPY-1.5 (between power control section and processor)

See page 2-5 for sectional views of these cables if using equivalent cables.

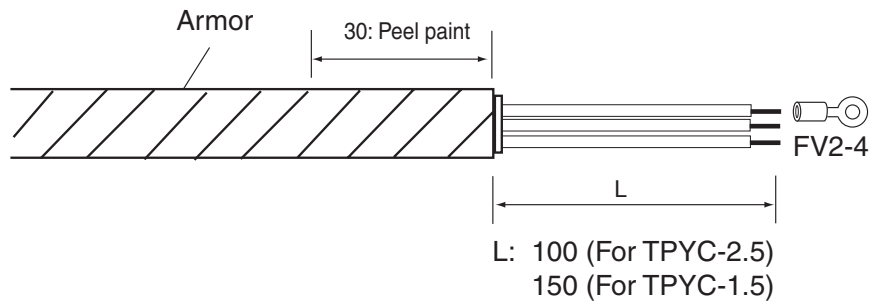

Terminal TB3: #1-#3 TPYCY-2.5 (between power control section and antenna)

Terminal TB3: #6, #8, #9 TPYCY-1.5 (between power control section and antenna)

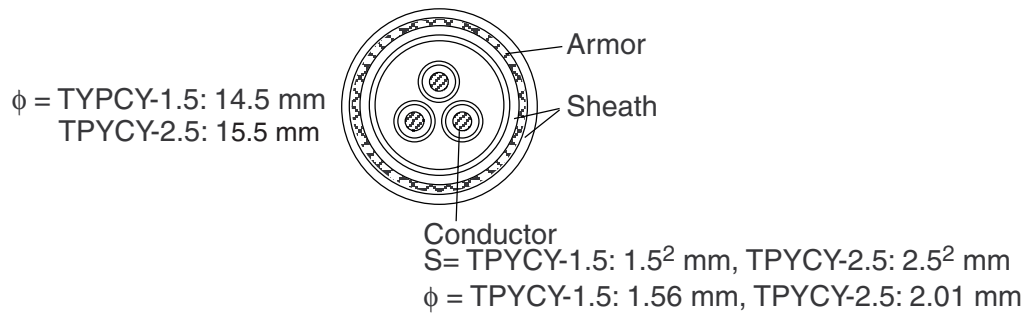
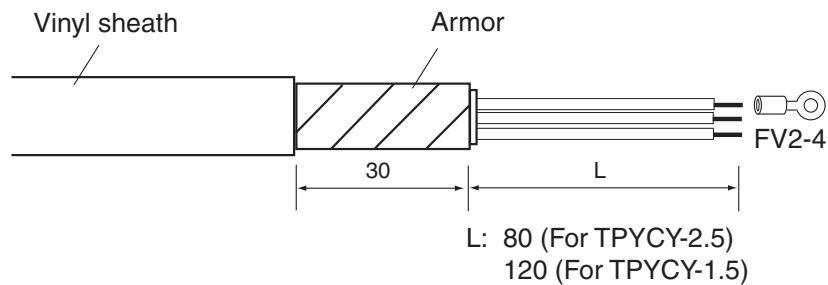

2.6 Changing AC Power Specification

To change AC power specification from 100 VAC to 220 VAC and vice versa, change fuse and jumper wire setting, following the instructions in this section.

Processor unit

As directed in the table below, add or remove jumper connector P108 from the PWR board 03P9339 and change the fuse in the processor unit according to ship's mains. Then, adjust the overvoltage detection circuit, the procedure for which is shown on the next page.

Note: When switching from 220 VAC to 100 VAC, construct a jumper connector locally, referring to the illustration on the next page. (VH8 connector housing is to be plugged into J108.)

Power supply	Fuse	Jumper connector P108
100 VAC	10A	Necessary
220 VAC	5A	Unnecessary

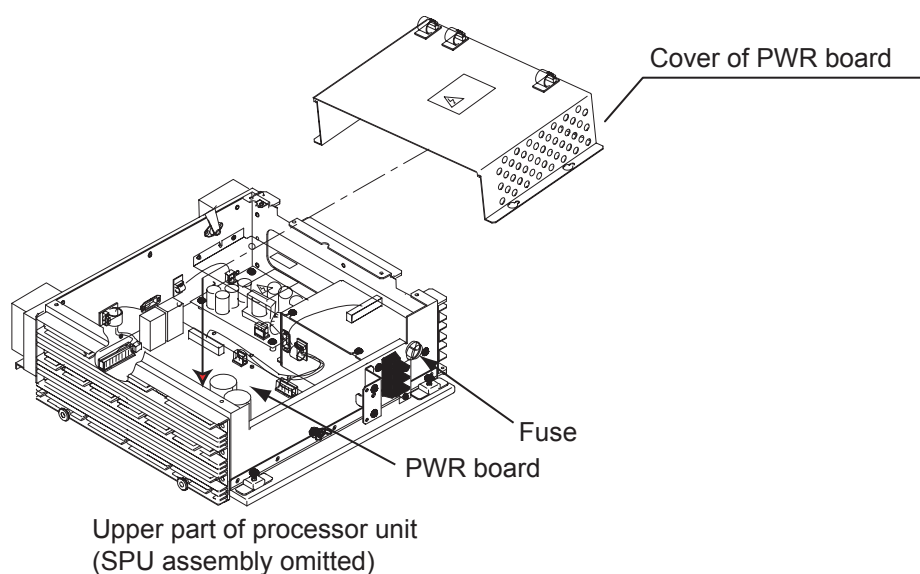

Processor unit, inside view

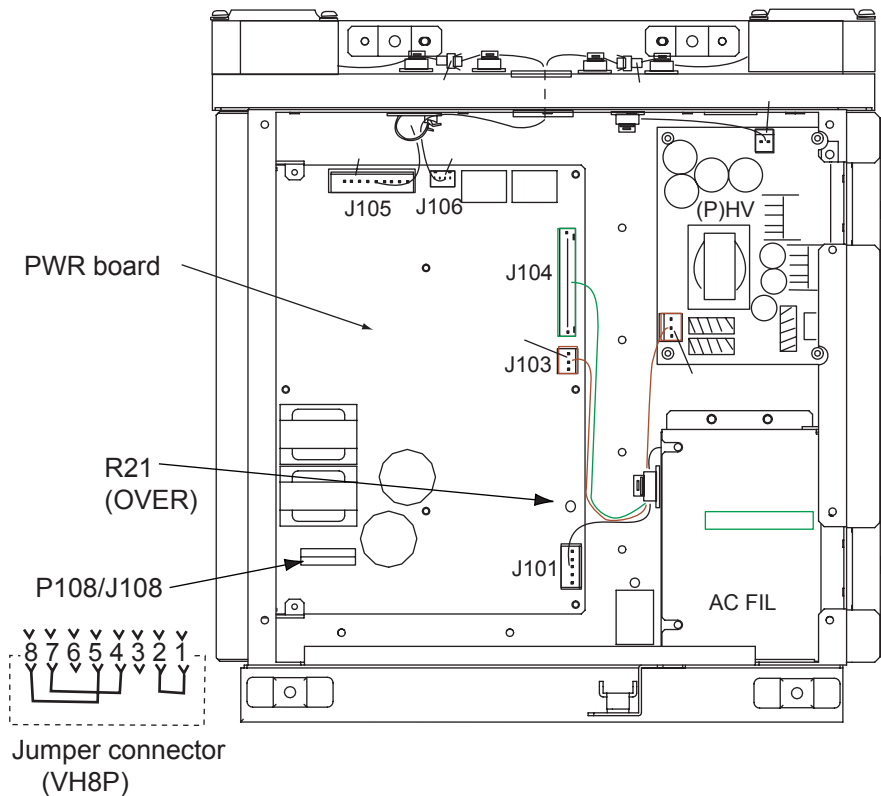

Processor unit, inside view

How to adjust the overvoltage detection circuit:

1. Add or remove the jumper connector P108 as appropriate and change the fuse, referring to the table on the previous page for details.
2. On the PWR board, set R21 fully clockwise.
3. Connect a variable transformer between ship's mains and the input power terminal board TB-1 in the processor unit.
4. Adjust the variable transformer output (i.e., input voltage to the processor unit) as follows:
 For 100 VAC set: 144 VAC
 For 220 VAC set: 288 VAC
5. Turn on the radar and rotate R21 counterclockwise gradually until the overvoltage detection circuit activates (i.e., power supply cuts off).
6. Lower the output voltage of the variable transformer and confirm that the radar automatically turns on with a voltage lower than 142 VAC or 284 VAC.
7. Gradually increase the output voltage of the variable transformer and confirm that the overvoltage detection circuit activates at 144 V or 288 VAC of the variable transformer output.
8. Assemble and connect the processor unit.

Power supply unit

Refer to the illustration and table below to add (or remove) jumper connector P8 from the TX-HV Board (03P9350) and change fuse.

After completing jumper and fuse arrangements, adjust the overvoltage detection circuit, using a variable transformer.

Note: When switching from 220 VAC to 100 VAC, construct a jumper connector locally, referring to the illustration below. (VH6 connector housing is to be plugged into J8.)

Power	Fuse	Jumper connector P8
100 VAC	5A	Required
220 VAC	3A	Unnecessary

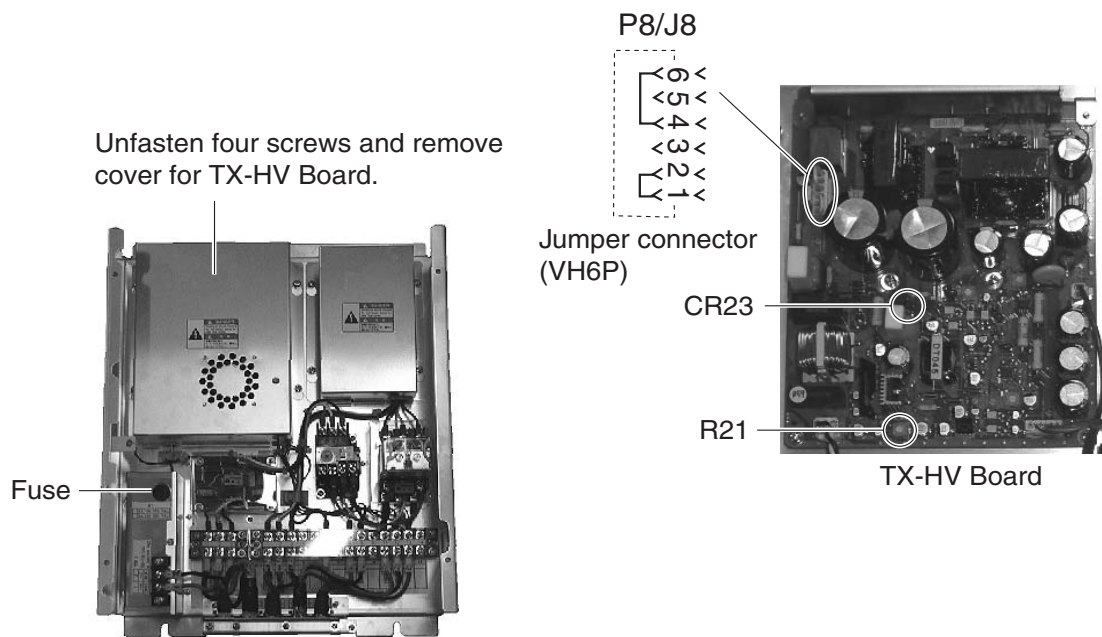

How to adjust the overvoltage detection circuit

1. Add or remove the jumper connector P8 as appropriate and change the fuse, referring to the table above for details.
2. On the PWR board, set R21 fully clockwise.
3. Connect a variable transformer between ship's mains and the input power terminal board TB-1 in the processor unit.
4. Adjust the variable transformer output (i.e., input voltage to the processor unit) as follows:
 - For 100 VAC set: 144 VAC
 - For 220 VAC set: 288 VAC
5. Turn on the radar and rotate R21 counterclockwise gradually until the overvoltage detection circuit activates (i.e., power supply cuts off).
6. Lower the output voltage of the variable transformer and confirm that the radar automatically turns on with a voltage lower than 142 VAC or 284 VAC.
7. Gradually increase the output voltage of the variable transformer and confirm that the overvoltage detection circuit activates at 144 V or 288 VAC of the variable transformer output.
8. Assemble and connect the power supply unit.

3. ADJUSTMENTS

This section provides the information necessary for setting and adjusting the radar, which is carried out from the radar's menu system. Menus may be accessed from the keyboard or on-screen menu in case of Control Unit RCU-014, or on-screen menu in case of Control Unit RCU-015.

The menu illustrations in this chapter show default settings in bold face.

3.1 Initializing Tuning

1. Transmit the radar on 48 nm range.
2. Rotate the [GAIN] control until the value on the gain bar is 70-80.
3. Left-click the MENU box at the right side of the screen.
4. Spin the thumbwheel to choose 1 ECHO and then push the thumbwheel.

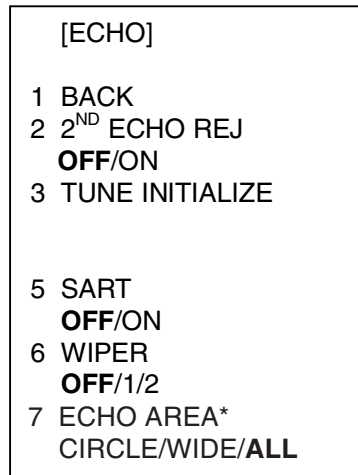

* Not available with IMO radar

ECHO menu

5. Spin the thumbwheel to choose 3 TUNE INITIALIZE.
6. Push the thumbwheel to initialize automatic tuning.

In a few moments echoes appear on the screen. The message "TUNE INITIALIZE" appears (in red) during automatic tuning. When this message disappears, the tuning is completed. If necessary adjust the [GAIN] control to show echoes clearly.

7. Push the right button twice to close the menu.

3.2 Heading Alignment

You have mounted the antenna unit facing straight ahead in the direction of the bow. Therefore, a small but conspicuous target dead ahead visually should appear on the heading line (zero degrees). In practice, you will probably observe some small bearing error on the display because of the difficulty in achieving accurate initial positioning of the antenna unit. The following adjustment will compensate for this error.

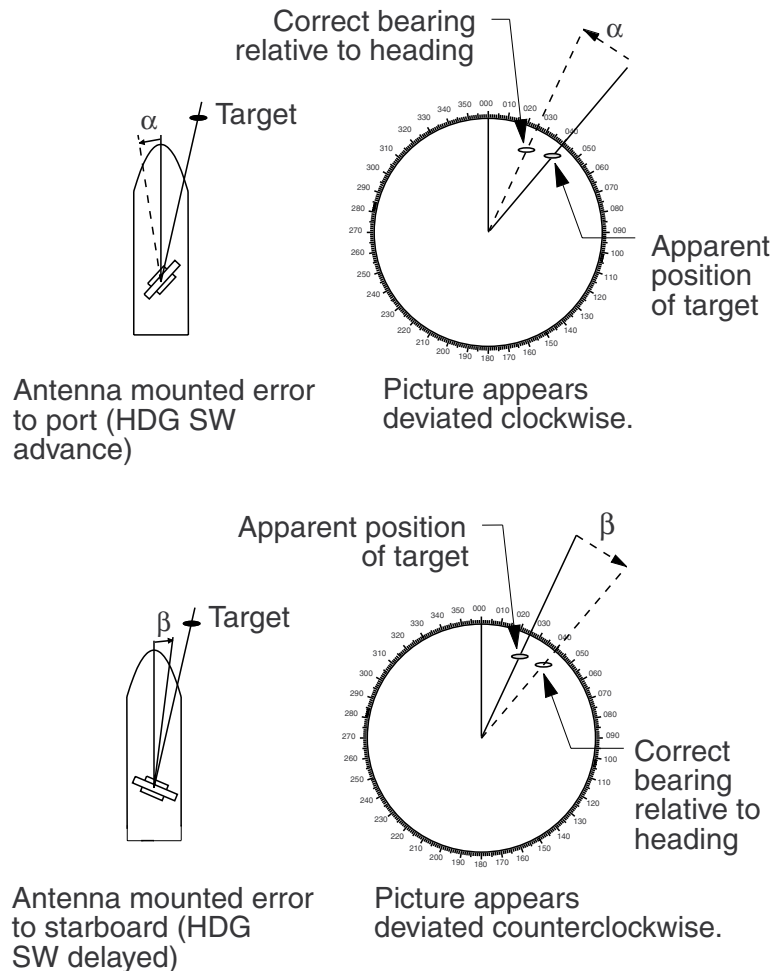

Heading alignment

1. Select a stationary target echo at a range between 0.125 and 0.25 nm, preferably near the heading line.
2. Operate the EBL control to bisect the target echo:
 - a) Roll the trackball to place the arrow in the EBL1 or EBL2 box (at bottom left corner), whichever EBL you want to use.
 - b) Push the left button to turn on the EBL.
 - c) Push the left button again to send the cursor inside the effective display area.
 - d) Roll the trackball (coarse adjustment) or spin the thumbwheel (fine adjustment) to bisect the target with the EBL.
3. Read the target bearing.
4. Measure the bearing of the stationary target on the navigation chart and calculate the difference between actual bearing and apparent bearing on the radar screen.
5. Left-click the MENU box at the right side of the screen to close the menu.

6. For Control Unit RCU-014:

- a) While pressing and holding down the [HL OFF] key, press the [MENU] key five times.
- b) Press the [0] key to show the INITIALIZE menu.

For Control Unit RCU-015:

See the procedure on the next page for how to show the INITIALIZE menu.

[INITIALIZE]
1 BACK
2 [ECHO ADJ]
3 [SCANNER]
4 [INSTALLATION]
5 [OWN SHIP INFO]
6 [ARP PRESET]
7 [NETWORK]
8 [OTHER]

INITIALIZE menu

- 7. **RCU-014:** Press the [2] key to open the ECHO ADJ menu.
RCU-015: Choose 2 ECHO ADJ and then push the thumbwheel.

[ECHO ADJ]
1 BACK
2 CABLE ATT ADJ AUTO/MANUAL 30
3 HD ALIGN 000.0°
4 TIMING ADJ 0
5 MBS 0
6 DEFAULT ANT HEIGHT 5/7.5/10/15/20/ 25/30/35/40/45/ more 50 m
7 NEAR STC CURVE 2/2.5/3/3.5
8 MID STC CURVE 3/4/5/6
9 FAR STC CURVE 6/7/8
0 RING SUPPRESSION 0

ECHO ADJ menu

- 8. **RCU-014:** Press the [3] key to choose HD ALIGN.
RCU-015: Choose 3 HD ALIGN and then push the thumbwheel.
- 9. **RCU-014:** Key in the bearing difference. The setting range is 0 to 359.9(°).
RCU-015: Spin the thumbwheel to set the bearing difference and then push the thumbwheel. The setting range is 0 to 359.9(°).
- 10. Confirm that the target echo is displayed at correct bearing on the screen and then push the thumbwheel.
- 11. **RCU-014:** Press the [MENU] key to finish.
RCU-015: Left-click the MENU box to finish.

How to access the INITIALIZE Menu with Control Unit RCU-015



1. Use the trackball to place the pointer on the MENU box so it is highlighted. DO NOT click the menu box - just leave the pointer over "MENU".

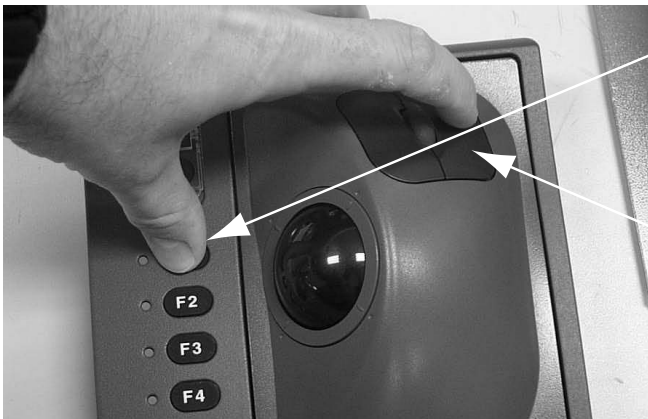

2. Press and hold down the F1 key. Keep it held down during the next step.

3. Push the right button five times. You should hear three beeps on the fifth push.



The INITIALIZE menu appears. Choose 4 INSTALLATION to show the installation menus.

Menu operation with trackball module

1. Roll the trackball to choose the MENU box and then push the thumbwheel or left button.
2. Spin the thumbwheel to choose menu item and then push the thumbwheel or left button.
3. Spin the thumbwheel to choose menu option and then push the thumbwheel or left button.
4. Left-click the MENU box to close the menu.

3.3 Adjusting Sweep Timing

Sweep timing differs with respect to the length of the signal cable between the antenna unit and the processor unit. Adjust sweep timing to prevent the following symptoms:

- The echo of a "straight" target (for example, pier), on the 0.25 m range, will appear on the display as being pulled inward or pushed outward. See the figure below.
- The range of target echoes will also be incorrectly shown.

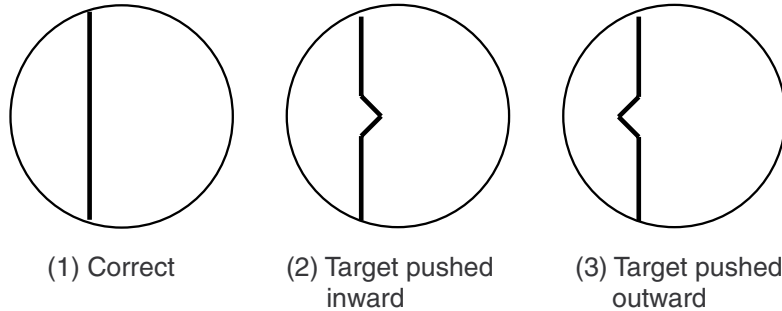

Examples of correct and incorrect sweep timings

1. Transmit on the 0.25 nm range.
2. Adjust the radar picture controls to display picture properly.
3. Select a target echo which should be displayed straightly.
4. On the ECHO ADJ menu, On the ECHO ADJ menu, choose 4 TIMING ADJ.

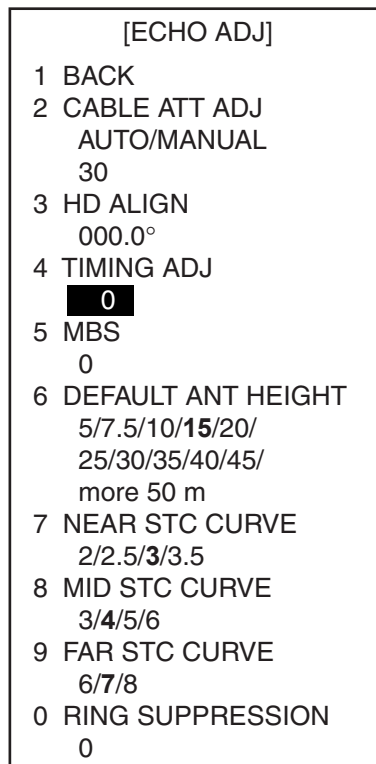

ECHO ADJ menu

5. Spin the thumbwheel to set a suitable value which causes the target to be displayed straightly. The setting range is 0 to 4095.
6. Left-click the MENU box to finish.

3.4 Suppressing Main Bang

If main bang appears at the screen center, suppress it as follows.

1. Transmit the radar on a long range and then wait ten minutes.
2. Adjust gain to show a slight amount of noise on the display.
3. Select the 0.25 nm range. Adjust sea clutter control to suppress sea clutter.
4. On the ECHO ADJ menu, choose 5 MBS.

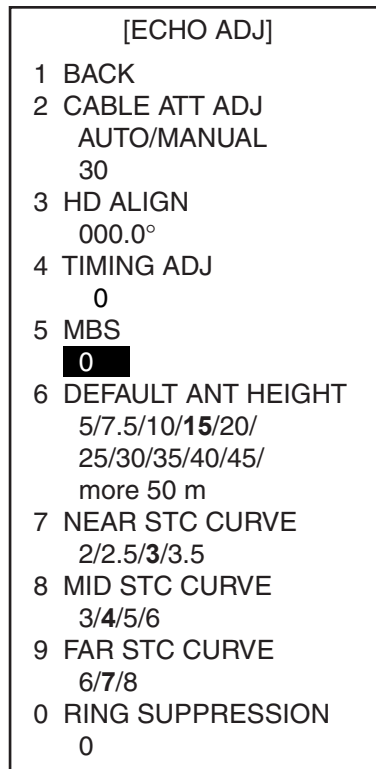

ECHO ADJ menu

5. Spin the thumbwheel to set a suitable value so that the main bang disappears. The setting range is 0 to 255.
6. Left-click the MENU box to finish.

3.5 Other Settings

ECHO menu setting

Open the ECHO ADJ menu as described on page 3-3 and 3-4.

[ECHO ADJ]	
1	BACK
2	CABLE ATT ADJ AUTO/MANUAL 30
3	HD ALIGN 000.0°
4	TIMING ADJ 0
5	MBS 0
6	DEFAULT ANT HEIGHT 5/7.5/10/15/20/ 25/30/35/40/45/ more 50 m
7	NEAR STC CURVE 2/2.5/3/3.5
8	MID STC CURVE 3/4/5/6
9	FAR STC CURVE 6/7/8
0	RING SUPPRESSION 0

ECHO ADJ menu

CABLE ATT ADJ

Before adjusting, set the radar as follows:

IR: 2, ES: off, EAV: off, 24nm range, long pulse

(Same as default setting of PICTURE1)

To adjust the cable attenuation manually, choose MANUAL and push the thumbwheel. With the gain set to 80, spin the thumbwheel until noise just appears on the screen. Default setting is 30 for the antenna cable length of 15 m. The setting range is 0 to 73.

To adjust the cable attenuation automatically, choose AUTO and push the thumbwheel. The message "CABLE ATT ADJ" appears (in red) at the bottom of the screen. It takes about five minutes to complete the adjustment, after which the radar goes into stand-by.

DEFAULT ANT HEIGHT

Select height (m) of the radar antenna unit from the sea surface from among 5, 7.5, 10, 15, 20, 25, 30, 35, 40, 45 and "more 50 m".

NEAR STC CURVE, MID STC CURVE AND FAR STC CURVE

The default setting is suitable for most conditions. If necessary, change the setting according to sea conditions.

RING SUPPRESSION

This is mainly used to remove "ring" noise that appears in the waveguide-type radar. Adjust so the rings disappear at the range of 0.125 nm. The setting range is 0 to 255.

SCANNER menu

1. Open the INITIALIZE menu as described on page 3-3 and 3-4.
2. Choose 3 SCANNER to open the SCANNER menu.

	[SCANNER]
1	BACK
2	BLIND SECTOR 1 START 000° ANGLE 000°
3	BLIND SECTOR 2 START 000° ANGLE 000°
4	ANT REVOLUTION LO/HI/ AUTO
5	ANT SW OFF/ ON
6	ANT STOPPED STBY/TX
7	M SPEC OFF/ON
8	BB TYPE NORMAL/BB

SCANNER menu

BLIND SECTOR 1 and BLIND SECTOR 2

Set area (up to 2) where no radar pulses will be transmitted. Heading should be adjusted before setting any blind sector. For example, set the area where an interfering object at the rear of the antenna would produce a dead sector (area where no echoes appear) on the display. To enter an area, enter start bearing (relative to heading) and dead sector angle. To erase the area, enter 0 for both the START and ANGLE options. The setting range of START is 0 to 359° and ANGLE is 0 to 180°.

ANT REVOLUTION

No use.

ANT SW and ANT STOPPED

This is used for antenna maintenance by service personnel.

M SPEC

No use.

BB TYPE

Choose type of radar. Select "BB" for FAR-2167DS-BB.

INSTALLATION menu

Open the INSTALLATION menu by choosing 4 INSTALLATION from the INITIALIZE menu.

RADAR

Choose main radar or sub radar.

RANGE UNIT

Choose NM, SM, km or kyd (kilo yard) as appropriate. For the IMO- and A-type radars the range unit is fixed at "NM".

RADAR NO and RADAR POSN

For multiple radar system using the network hub, set number (name) and antenna position for each system, to easily distinguish radars from one another.

MODEL

Choose "60".

TYPE

Choose radar type from among the following options:

IMO: IMO compliant

A: Near-IMO specifications

B: International fishing vessels

C: Japanese flag vessels

W: Washington state (USA) ferry

ON TIME and TX TIME

These items show number of hours the radar has been turned on and transmitted, respectively. Value can be changed; for example, after replacing magnetron TX Time can be reset to 0.

[INSTALLATION]	
1	BACK
2	RADAR MAIN/SUB
3	RANGE UNIT* ¹ NM/SM/km/kyd
4	RADAR NO* ² 1/2/3/4/5/6/7/8
5	RADAR POSN FORE/MAIN TOP/ MAIN 2ND/MAIN 3RD/ AFT/PORT/ STARBOARD
6	MODEL 6/12/25 UP/25 DOWN/ 50/30 UP/30 DOWN/60
7	TYPE IMO/A/B/C/W
8	ON TIME XX.XH
9	TX TIME XX.XH

*1: Not shown on IMO- or A-type radar.

*2: No.1-4: with antenna unit
No.5-8: without antenna unit

INSTALLATION menu

OWN SHIP INFO menu

Open the OWN SHIP INFO menu by choosing 5 OWN SHIP INFO from the INITIALIZE menu.

[OWNSHIP INFO]	
1	BACK
2	LENGTH/WIDTH
	LENGTH 100 m
	WIDTH 50 m
3	SCANNER POSN
	BOW 0 m
	PORT 0 m
4	GPS1 ANT POSN
	BOW 0 m
	PORT 0 m
5	GPS2 ANT POSN
	BOW 0 m
	LEFT 0 m
6	CONNING POSN
	BOW 0 m
	PORT 0 m

OWN SHIP INFO menu

LENGTH/WIDTH and SCANNER POSN

To accurately inscribe own ship marker on the screen, enter length and width of the ship and antenna position from the bow and left sides. The setting ranges are as follows:

LENGTH: 0 to 999 m

WIDTH: 0 to 99 m

BOW: 0 to 999 m

LEFT: 0 to 99 m

GPS 1 ANT POSN and GPS 2 ANT POSN

This is for AIS. Enter the GPS antenna position, from the bow and left side. The setting ranges are the same as above.

CONNING POSN

Enter the conning position, from the bow and left side. The setting ranges are the same as those shown on the preceding page. When you set the reference point as the conning position, these values are used to correct the radar antenna position.

Note: If two or more radars are installed, all items on the OWN SHIP INFO menu should be the same except 3 SCANNER.

ARPA PRESET menu

Open the ARPA PRESET menu by choosing 6 ARP PRESET from the INITIALIZE menu.

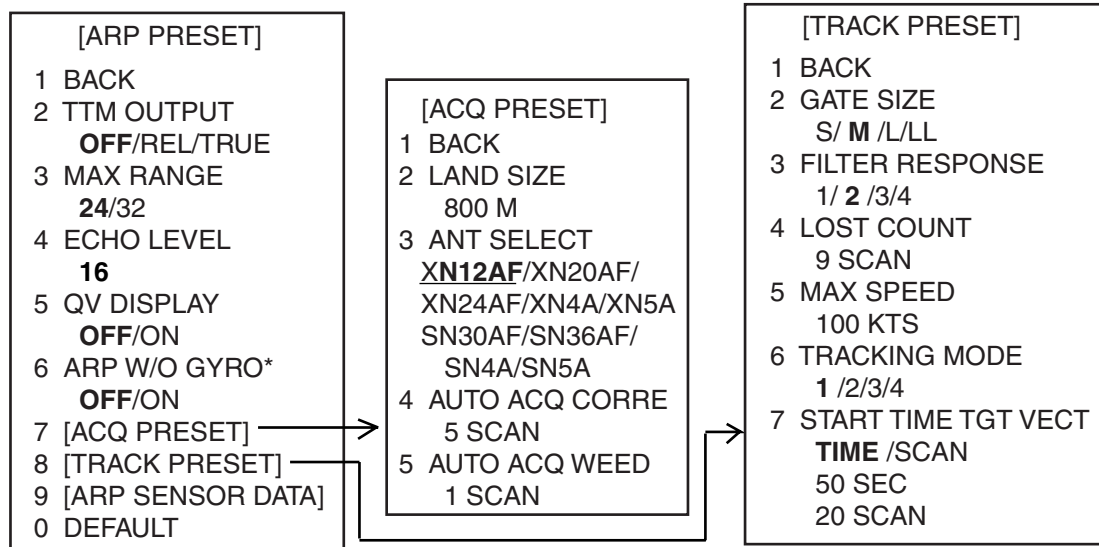

*: Not shown on IMO radar.

ARP-related menus

TTM OUTPUT

Set the output format of tracked targets among OFF, REL and TRUE.

OFF: No output

REL (relative): Target bearing from own ship, degree relative.
Target course, degree relative.

TRUE: Target bearing, degree true.
Target course, degree true.

Note: The TTM OUTPUT port changes according to the setting for INS as described on page 3-13.

INS-OFF: Output from J619 port

INS-SERIAL: Output from J620 port

INS-LAN: Output from NETWORK port

MAX RANGE

Choose the maximum ARPA tracking range, 24 or 32 nm.

ECHO LEVEL

Set echo detection level. The setting range is 1 to 31.

QV DISPLAY

OFF: Normal picture

ON: Quantized picture. Always off at power on.

ARP W/O GYRO (Not shown on IMO radar)

ARPA may be used without a gyrocompass. Choose ON to use ARPA without a gyrocompass.

LAND SIZE

Set the minimum echo size to be considered a landmass. The setting range is 100 to 1000 m, in increments of 100 m.

ANT SELECT

Set the model of antenna radiator used.

AUTO ACQ CORRE

Set the number of consecutive echoes to receive from a target before initiating automatic acquisition on it. The setting range is 3 to 10.

AUTO ACQ WEED

Set the number of consecutive "no echoes" from a target before canceling automatic acquisition on it. The setting range is 1 to 5.

GATE SIZE

Set the gate size among S, M, L, or LL.

FILTER RESPONSE

Set the filter response function. The setting range is 1 to 4. Choose 1 for better trackability; 4 for better stability.

LOST COUNT

Set the number of consecutive "no echoes" before an acquired target is declared as a lost target. The setting range is 1 to 20.

MAX SPEED

Set the maximum tracking speed. The setting range is 40 to 150.

TRACKING MODE

Set the tracking mode among 1 to 4.

START TIME TGT VECT

Choose how to wait from time of acquisition to display of vector. Choose TIME to set by time (seconds) or SCAN to set by number of antenna scans.

OTHER menu

Open the OTHER menu by choosing 8 OTHERS from the INITIALIZE menu.

	[OTHERS]
1	BACK
2	DEMO ECHO OFF/EG/SPU/PC
3	EAV w/o GYRO OFF/ON
4	ARP SELECT ARPA/ATA
5	INS OFF/SERIAL/LAN

OTHER menu

EAV w/o GYRO

Echo averaging can be used without a gyrocompass. Choose ON to use echo averaging without a gyrocompass.

ARP SELECT

Choose ARPA or ATA depending on your radar system.

INS

Choose appropriate item according to the ECDIS connected.

OFF: No connection

SERIAL: When connecting FEA-2105 series ECDIS.

LAN: When connecting FEA-2107 series ECDIS.

This page intentionally left blank.

4. OPTIONAL EQUIPMENT

4.1 Gyro Converter GC-10

The Gyro Converter GC-10, incorporated inside the processor unit, converts analog gyrocompass reading into digital coded bearing data for display on the radar screen.

This section explains how to install the GC-10 (mainly consisting of the GYRO CONVERTER board) and set it up according to the gyrocompass connected.

Installing the GYRO CONVERTER board

Necessary Parts: Gyro Converter GC-10-2 (Code no. 000-080-440)

See packing list at the back of this manual for details.

1. Open the processor unit.

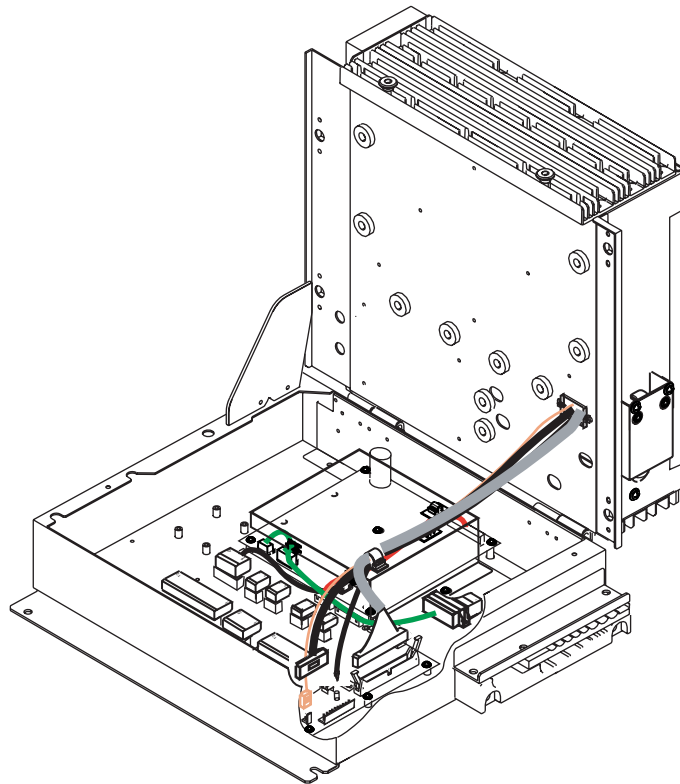

Processor unit, inside view

2. Fasten the GYRO CONVERTER board inside the processor unit with five washer head screws.
3. Fix connector 231-607/019-FUR (called J602) with two screws.

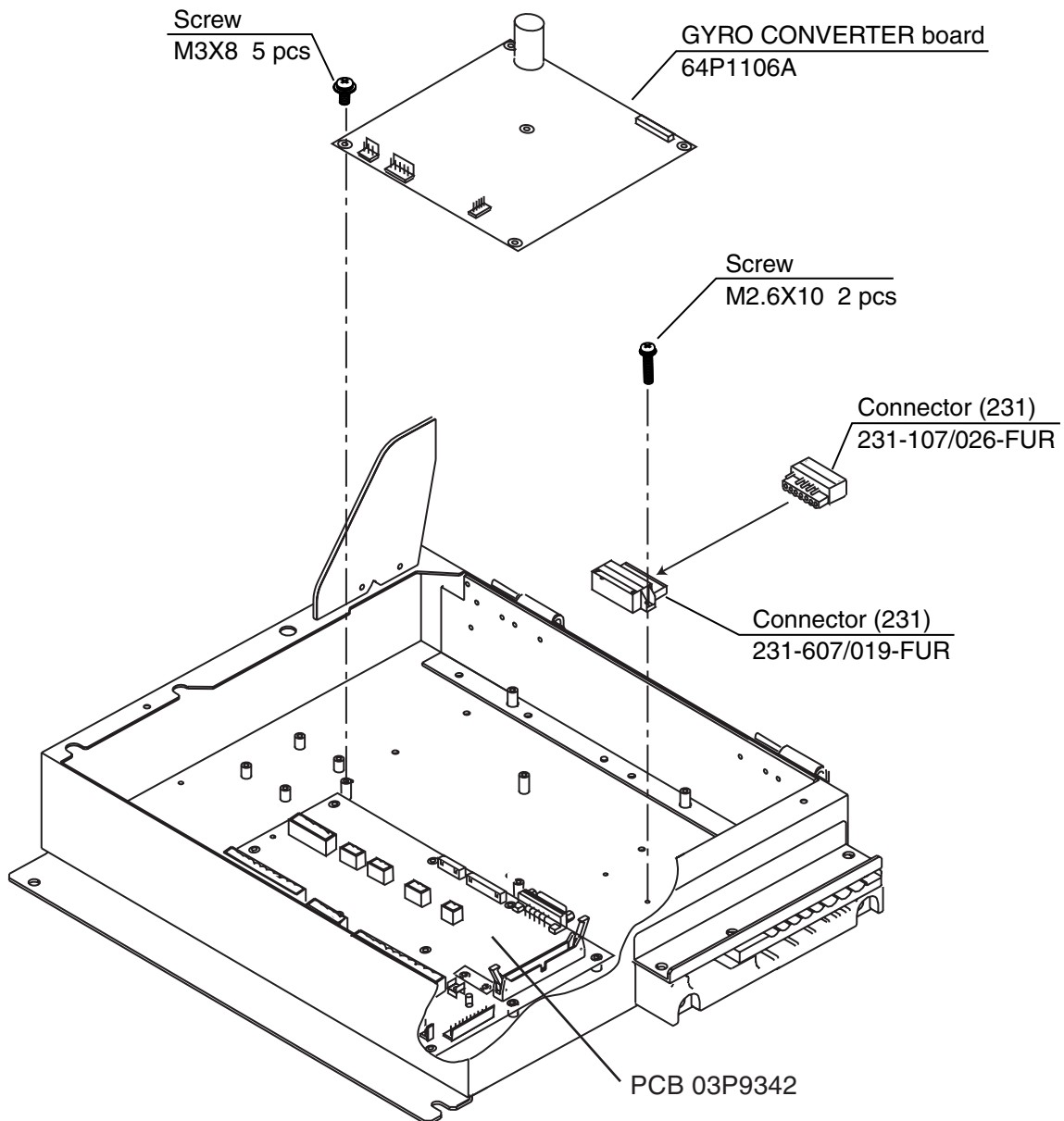

Fixing GYRO CONVERTER board inside the processor unit

4. Connect the GYRO CONVERTER board to the 03P9342 board with XH-PH 03-2088 connector assy. (6-14P) and NH connector assy. 03-2091.

5. Connect J602 (attached at step 3) to the GYRO CONVERTER board with two VH connector assemblies 03-2089 (3P) and 03-2090 (5P).

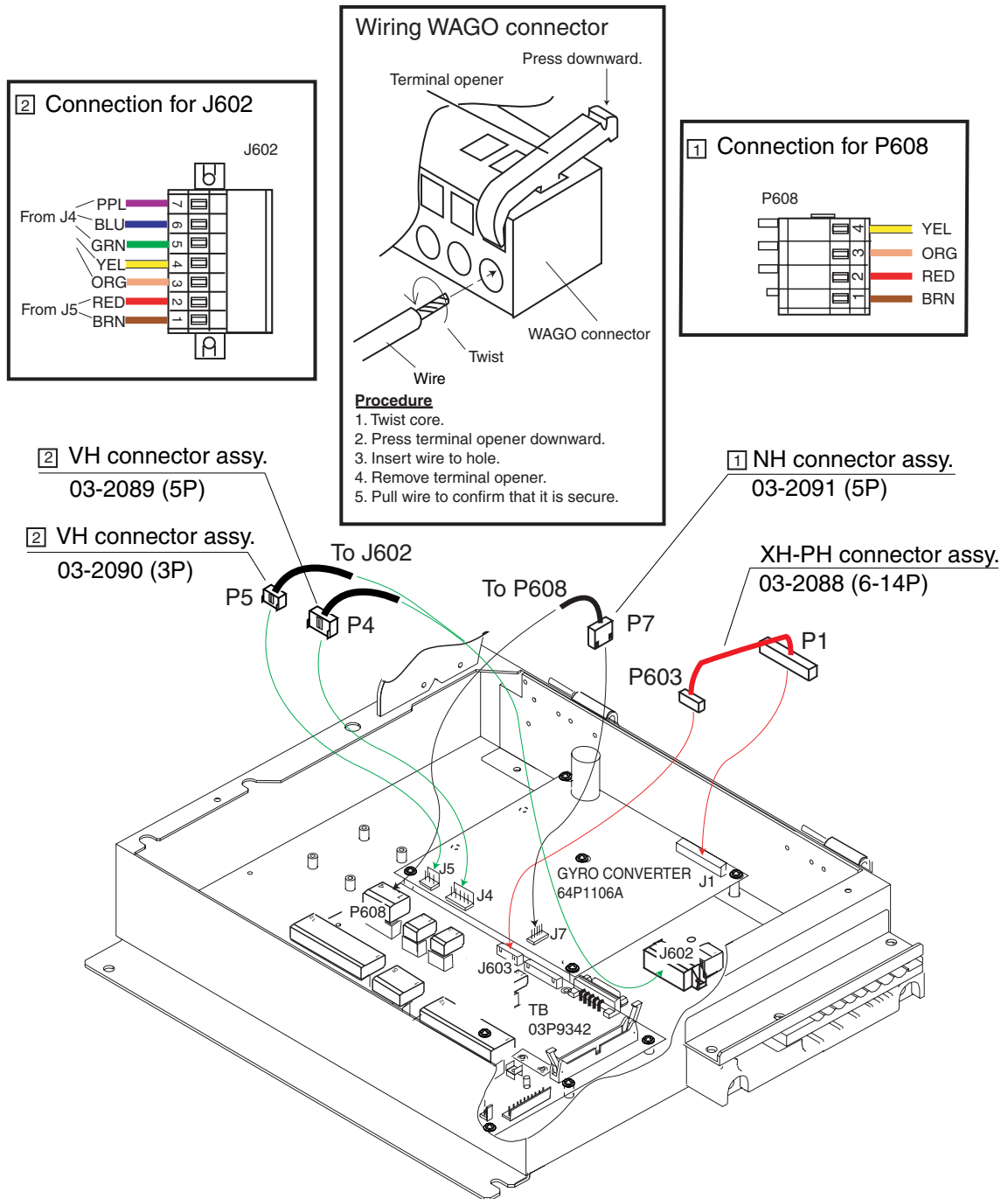

Connecting connector assemblies inside processor unit

6. Confirm gyrocompass specifications and set up the DIP switches and jumper wires on the GYRO CONVERTER board according to gyrocompass connected:
- Setting jumper wires and DIP switches by gyrocompass specifications: page 4-6
 - Setting jumper wires and DIP switches by make and model of gyrocompass: page 4-7
 - Location of jumper wires and DIP switches: page 4-8

7. Pass the gyrocompass cable through the cable clamp and connect it to connector J602 as shown in the figure below.
8. Attach the clamps to the plastic cover and then attach the cover to the GYRO CONVERTER board as shown in the figure below. Pass cables thru the clamp ED-1.

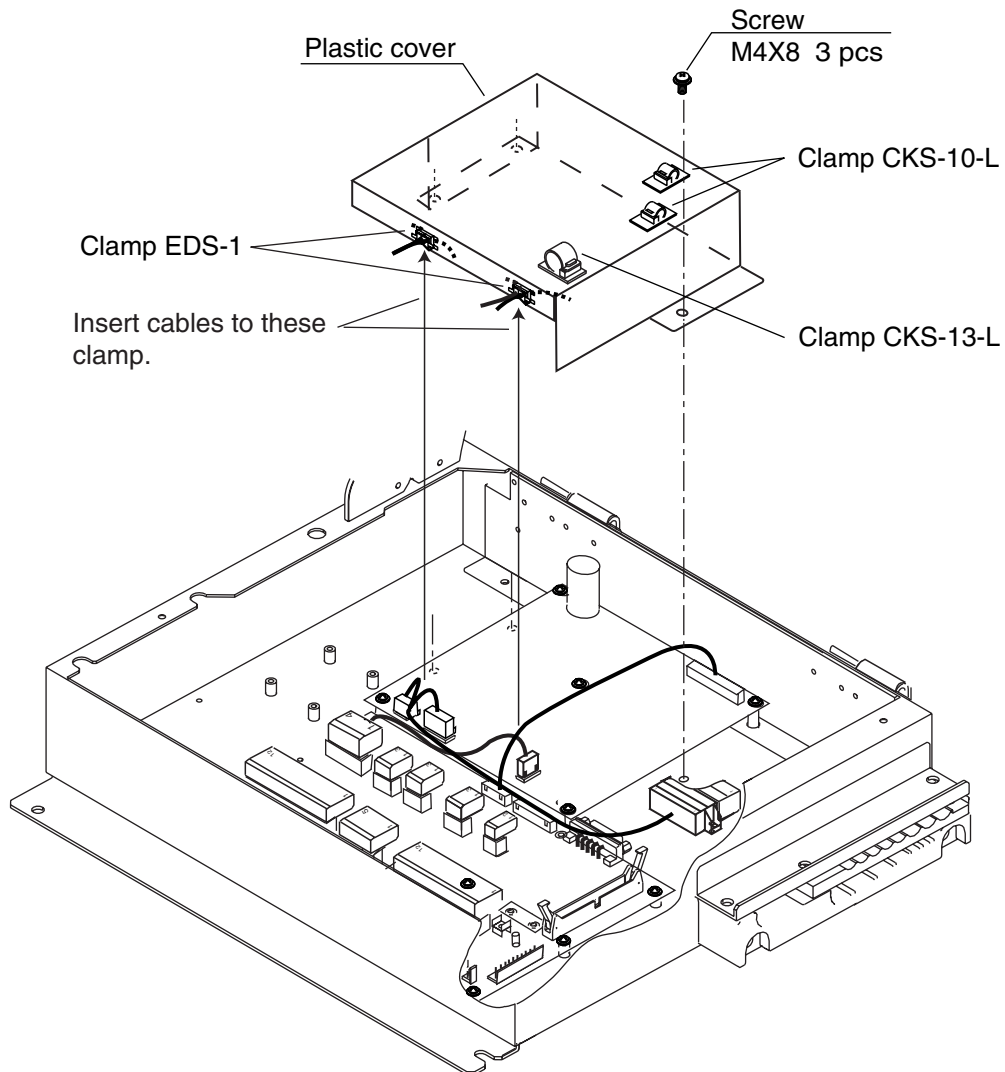

Attaching plastic cover for GYRO CONVERTER board

9. Close the processor unit.

Connection of external power supply

An external power supply is necessary when the repeater signal is step-by-step type and the step voltage is below 20 V or output voltage is less than 5 W.

1. Cut jumper wire JP1 on the GYRO CONVERTER board when an external power supply is used.
2. Connect the gyrocompass cable and power cable as shown below.

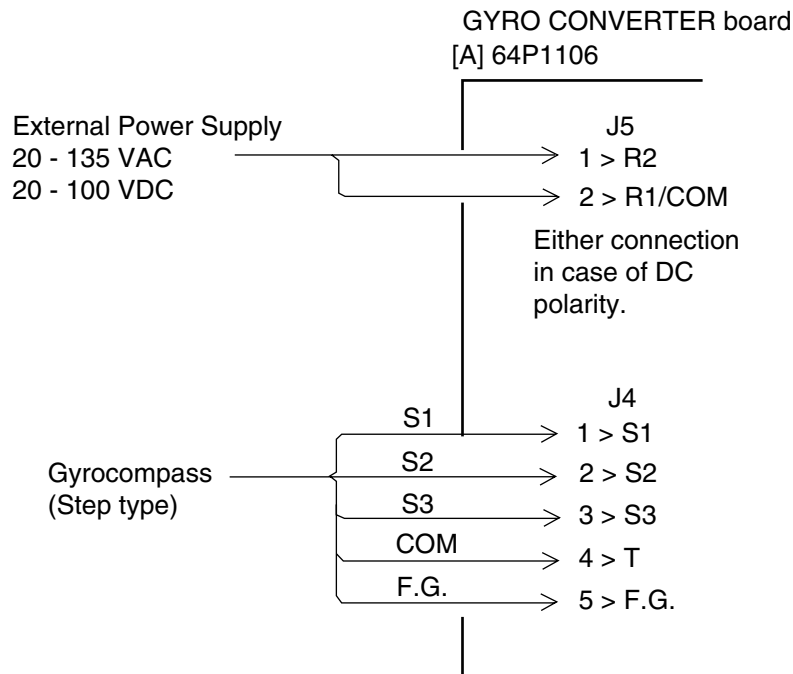

Connection of external power supply to GYRO CONVERTER board

DIP switch, jumper wire settings

Default setting

The gyro converter GC-10 is set at the factory for connection with the gyrocompass specifications below.

AC synchronous signal: 50/60 Hz
Rotor voltage: 60 V to 135 V AC
Stator voltage: 60 V to 135 V AC
Gear ratio: 360x
Supply voltage: 30 V to 135 V AC

If the specifications of the gyrocompass differ from those mentioned above, change jumper wire and DIP switch settings on the GYRO CONVERTER board. Settings may be changed according to gyrocompass specifications (see page 4-6) or make and model of gyrocompass (see page 4-7). For the location of DIP switches and jumper wires, see page 4-8.

Note: If you change the setting with the power turned on, set #8 of SW2 from OFF to ON, then OFF again to effect changes.

Setting method 1: DIP switch settings and gyrocompass specifications

1) Gyrocompass type

Gyrocompass type	SW 1-4	SW 1-5	SW 1-6	JP1
AC synchronous	OFF	OFF	OFF	#1, #2, #3
DC synchronous	OFF	OFF	OFF	#2, #3, #4
DC step	ON	OFF	OFF	#4, #5, #6
Full-wave pulsating current	OFF	ON	OFF	#4, #5, #6
Half-wave pulsating current	ON	ON	OFF	#4, #5, #6

2) Frequency

Frequency	SW 1-7	SW 1-8	Remarks
50/60 Hz	OFF	OFF	AC synchronous-pulsating current
400 Hz	ON	OFF	AC synchronous-pulsating current
500 Hz	OFF	ON	AC synchronous-pulsating current
DC	ON	ON	DC synchronous DC step

3) Rotor voltage (between R1 & R2)

Rotor Voltage	SW2-1	JP3
20 to 45 VAC	ON	#2
30 to 70 VAC	OFF	#2
40 to 90 VAC	ON	#1
60 to 135 VAC	OFF	#1

4) Stator voltage (between S1 & S2)

Stator Voltage	SW2-2	SW2-3	JP2
20 to 45 VAC, or 20 to 60 VDC	ON	OFF	#2
30 to 70 VAC, or 40 to 100 VDC	OFF	OFF	#2
40 to 90 VAC	ON	OFF	#1
60 to 135 VAC	OFF	OFF	#1

5) Ratio

Ratio	SW1-1	SW1-2	SW1-3
360X	OFF	OFF	OFF
180X	ON	OFF	OFF
90X	OFF	ON	OFF
36X	ON	ON	OFF

6) Supply voltage

Stator Voltage	JP4	JP5
20 to 45 VAC, or 20 to 60 VDC	#2	#2
30 to 70 VAC, or 40 to 100 VDC	#1	#1

7) AD-10 format data

Select data Tx interval for ports 1 to 6 with jumper wires JP6 and JP7. The Tx interval is available in 25 msec or 200 msec. Use 25 msec for radar.

8) NMEA-0183 Tx interval and output sentence

Tx interval	SW 2-5	SW 2-6	Output sentence
1 s	OFF	OFF	HDT+VHW
200 ms	ON	OFF	HDT
100 ms	OFF	ON	HDT
25 ms	ON	ON	HDT

9) NMEA-0183 Version no.

Version no.	SW3-1
1.5	OFF
2.0	ON

10) NMEA-0183 baud rate

Baud rate	SW3-2
4800 bps	OFF
38400 bps	ON

11) Power fail detection

Talker	SW3-3
Disable	OFF
Enable	ON

12) Stator signal loss detection

Detection	SW2-7
Yes	OFF
No	ON

(Use OFF for radar only) SW2-4: factory use only
SW3-4: not used

After setting jumpers and DIP switches, reset the power or set SW2-8 to "CPU".

Setting method 2: by make and model of gyrocompass

Maker	Models	Specification	SW 1-1	SW 1-2	SW 1-3	SW 1-4	SW 1-5	SW 1-6	SW 1-7	SW 1-8	SW 2-1	SW 2-2	SW 2-3	JP1	JP2	JP3	JP4	JP5	
Anschutz	Standard 2,3	AC synchronous 50/60Hz Rotor voltage: 50/60V Stator voltage: 22V 360x	OFF	OFF	OFF	OFF	OFF	OFF	OFF	OFF	OFF	ON	OFF	#1, #2,#3	#2	#2	#1	#	
	Standard 4,6	AC synchronous 50/60Hz Rotor voltage: 50/60V Stator voltage: 90V 360x	OFF	OFF	OFF	OFF	OFF	OFF	OFF	OFF	OFF	OFF	OFF	#1, #2,#3	#2	#1	#1	#	
	Standard 20	DC step 35V 180x COM(-), 3-wire(+)	ON	OFF	OFF	ON	OFF	OFF	ON	ON	-	ON	OFF	#4, #5,#6	#2	-	#2	#	
Yokogawa Navtec (Plath type)	C-1/1A/2/3 A-55, B-55	AC synchronous 50/60Hz Rotor voltage: 50/60V Stator voltage: 22V 360x	OFF	OFF	OFF	OFF	OFF	OFF	OFF	OFF	OFF	ON	OFF	#1, #2,#3	#2	#2	#1	#	
	CMZ-700	DC step 24V 180x COM(+), 3-wire(-)	ON	OFF	OFF	ON	OFF	OFF	ON	ON	-	ON	OFF	Remove	#2	-	*	*	
	CMZ-250X/ 300X/500	DC synchronous 360x	OFF	OFF	OFF	OFF	OFF	OFF	OFF	ON	ON	-	ON	OFF	Remove	#2	-	*	*
		DC step 35V 180x COM(+),3-wire(-)	ON	OFF	OFF	ON	OFF	OFF	OFF	ON	ON	-	ON	OFF	#4, #5,#6	#2	-	#2	#2
	CMZ-100/200/ 300 C-1Jr,D-1Z/1/3 IPS-2/3	AC synchronous 50/60Hz Rotor voltage: 100V Stator voltage: 90V 360x	OFF	OFF	OFF	OFF	OFF	OFF	OFF	OFF	OFF	OFF	OFF	OFF	#1, #2,#3	#1	#1	#1	#1
CMZ-50 See note below.	step 35V 180x COM(+),3-wire(-)	ON	OFF	OFF	ON	OFF	OFF	OFF	ON	ON	-	ON	OFF	Remove	#2	-	*	*	
Plath	NAVGAT III	AC synchronous 50/60Hz Rotor voltage: 50/60V Stator voltage: 68V 360x	OFF	OFF	OFF	OFF	OFF	OFF	OFF	OFF	OFF	OFF	OFF	#1, #2,#3	#2	#2	#1	#1	
Tokimec (Sperry type)	ES-1/2/11 GLT-101/102/ 103/106K/107	AC synchronous 50/60Hz Rotor voltage: 100/110V Stator voltage: 90V 36x	ON	ON	OFF	OFF	OFF	OFF	OFF	OFF	OFF	OFF	OFF	#1, #2,#3	#1	#1	#1	#1	
	ES-11A/110 TG-200 PR222R/2000 PR237L/H GM 21	AC synchronous 50/60Hz Rotor voltage: 100/110V Stator voltage: 22V 90x	OFF	ON	OFF	OFF	OFF	OFF	OFF	OFF	OFF	OFF	OFF	#1, #2,#3	#1	#1	#1	#1	
	MK-14 MOD-1/2/T NK-EN,NK-EI	DC step 70V 180x COM(-), 3-wire(+)	ON	OFF	OFF	ON	OFF	OFF	ON	ON	-	OFF	OFF	#4, #5,#6	#2	-	#1	#1	
	SR-130/140	DC step 70V 180x 5-wire, open collector	ON	OFF	OFF	OFF	ON	OFF	OFF	OFF	-	OFF	OFF	#4, #5,#6	#2	-	#1	#1	
	TG-100/5000 PR-357/130/ 140, ES-17 GLT-201/202 /203	DC step 70V 180x COM(+), 3-wire(-)	ON	OFF	OFF	ON	OFF	OFF	ON	ON	-	OFF	OFF	#4, #5,#6	#2	-	#1	#1	
	TG-6000	DC step 24V 180x	ON	OFF	OFF	ON	OFF	OFF	ON	ON	-	ON	OFF	#4, #5,#6	#2	-	#2	#2	
	GM-11	AC synchronous 50/60Hz Rotor voltage: 100V Stator voltage: 90V 90x	OFF	ON	OFF	OFF	OFF	OFF	OFF	OFF	OFF	OFF	OFF	#1, #2,#3	#1	#1	#1	#1	
	SR-120,ES-16 MK-10/20/30	DC step 35V 180x	ON	OFF	OFF	ON	OFF	OFF	ON	ON	-	ON	OFF	#4, #5,#6	#2	-	#2	#2	
Kawasaki	GX-81	AC synchronous 50/60Hz Rotor voltage: 100/110V Stator voltage: 90V 90x	OFF	ON	OFF	OFF	OFF	OFF	OFF	OFF	OFF	OFF	OFF	#1, #2,#3	#1	#1	#1	#1	
Armabrown	MK-10,MKL-1 SERIES1351, MOD-4	DC step 50V 180x COM(+), 3-wire(-)	ON	OFF	OFF	ON	OFF	OFF	ON	ON	-	OFF	OFF	#4, #5,#6	#2	-	#1	#1	
Robertson	SKR-80	DC step 35V 180x COM(-), 3-wire(+)	ON	OFF	OFF	ON	OFF	OFF	ON	ON	-	ON	OFF	#4, #5,#6	#2	-	#2	#2	

*: Set JP4 and JP5 according to the voltage of the external power supply.

Note: If CMZ-50 has 35 VDC, set JP1 to #4, #5, #6.

Location of DIP switches, jumper wires on the GYRO CONVERTER board

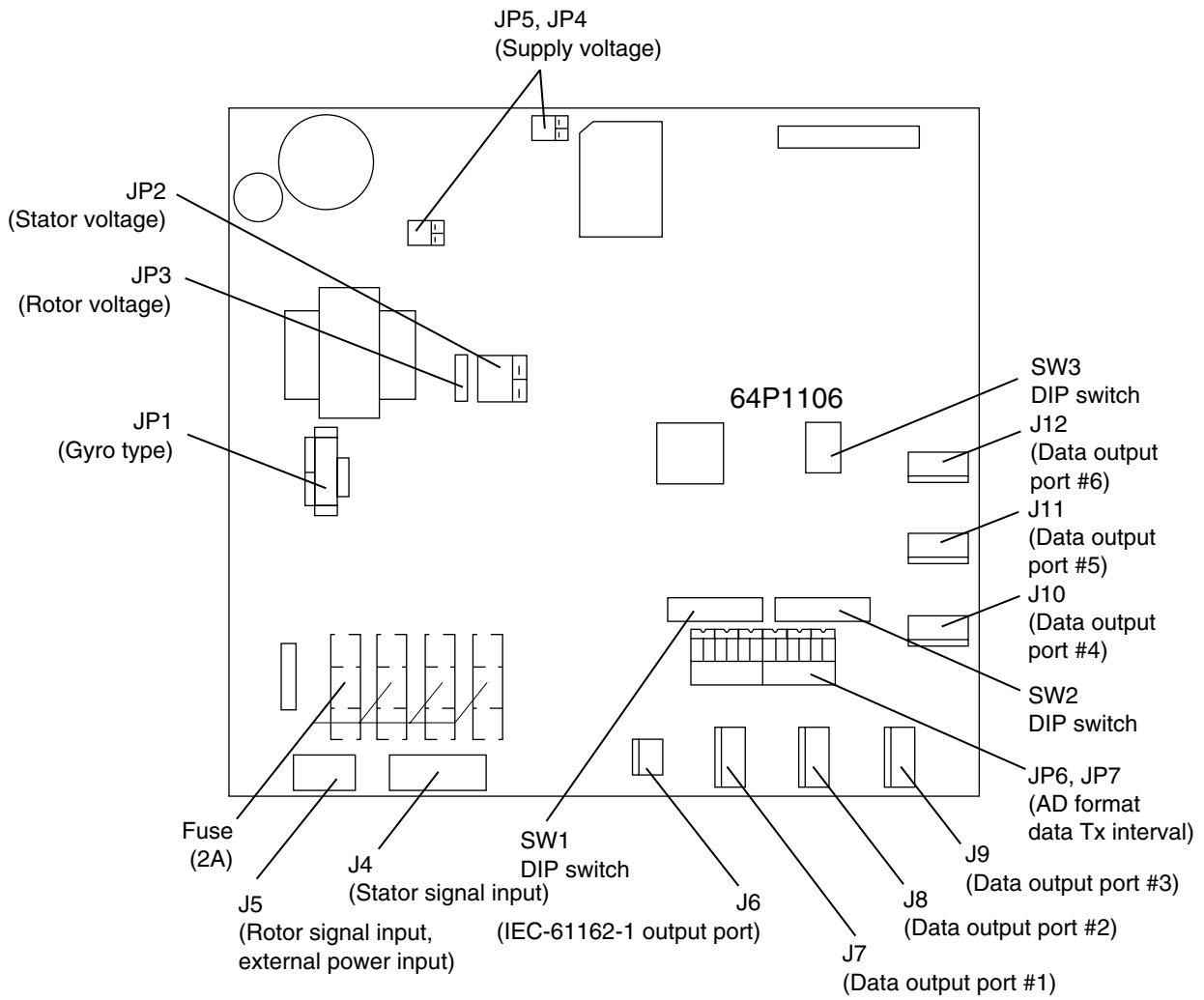

GYRO CONVERTER board

Setting the heading readout on the radar display

Confirm that the gyrocompass is giving a reliable readout. Then, set the heading readout on the radar display with the gyrocompass readout as follows:

1. Right-click the HDG box at the top right corner on the screen.

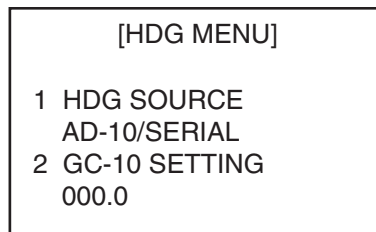

HDG menu

2. Spin the thumbwheel to choose 1 HDG SOURCE and push the left button.
3. Spin the thumbwheel to choose AD-10 and push the left button.
4. Spin the thumbwheel to choose 2 GC-10 SETTING and push the left button.
5. Spin the thumbwheel to set gyrocompass reading and push the left button.
6. Push the right button close the menu.

4.2 Memory Card Interface Unit

Mounting considerations

When selecting a mounting location, observe the following points:

- Locate the unit away from heat sources because of heat that can build up inside the cabinet.
- Locate the unit away from places subject to water splash and rain.
- Leave sufficient space at the sides and rear of the unit to facilitate maintenance.
- A magnetic compass will be affected if the unit is placed too close to the magnetic compass. Observe the compass safe distances on page ii to prevent interference to a magnetic compass.

Mounting procedure

Flush mounting

This unit can be flush-mounted in a panel with the standard installation materials.

1. Prepare a cutout in the mounting location, referring to the outline drawing at the end of this manual.
2. Screw in the threaded rods to the flange on the front panel of the unit securely by hands.
3. Set the unit to the cutout.
4. Insert the flat washer, spring washer and nut in that order for each rod and fasten the nuts.

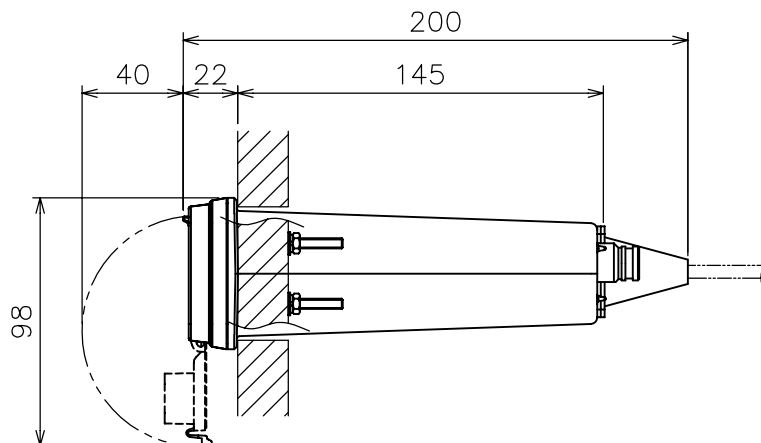
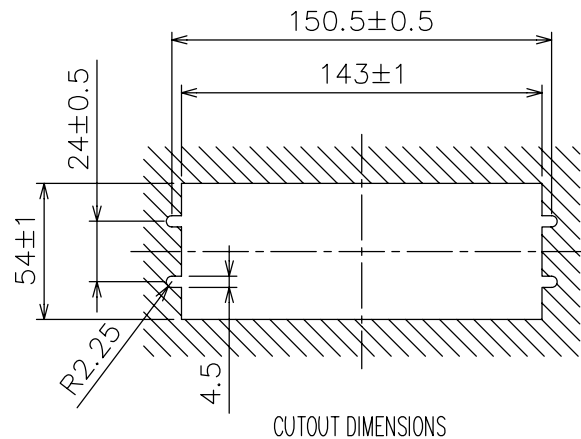

Desktop mount

Requires the optional desktop mount kit FP03-10201. Refer to the packing list at the back of this manual for further information about this kit.

1. Fix the mounting bracket 19-023-3081 to the unit with four screws.
2. Mount the above assembly on a desktop with four self-tapping screws.

Connections

One memory card IF unit and one processor unit

Connect as shown below.

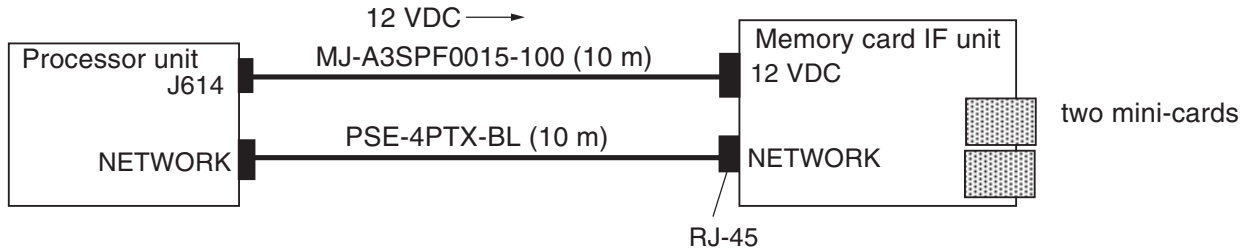

Connections one memory card interface unit

One memory card IF unit and multiple processor units

Prepare optional armored LAN cable kit and Switching Hub HUB-100. Connect as shown below.

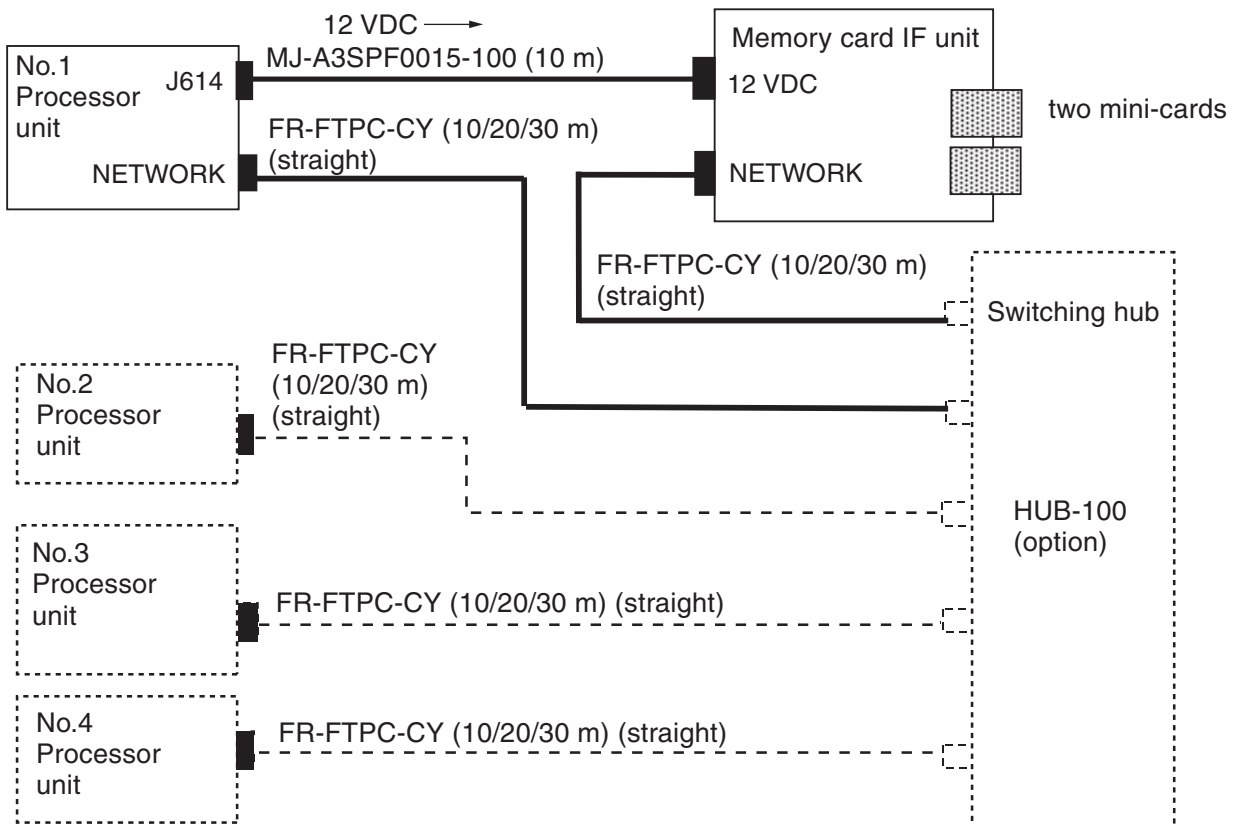

Connecting one memory card interface unit and multiple processor units via switching hub

Armored LAN cable kit

Type	Code No.	Contents
OP03-28900	000-082-658	Cable FR-FTPC-CY (10 m), Modular connector (2 pcs.)
OP03-28910	000-082-689	Cable FR-FTPC-CY (20 m), Modular connector. (2 pcs.)
OP03-28920	000-082-660	Cable FR-FTPC-CY (30 m), Modular connector (2 pcs.)

Note: When two memory card interface units are connected via a network, change ID code for the second unit.

1. Remove the cover and set the IP0 bit of the DIP switch S1 on the CARDCPU board (03P9333) to ON.
2. Set INIT bit of S1 to ON and turn on the radar. Wait until CR2 starts blinking. DO NOT turn off the power until CR2 starts blinking.
3. Turn off the power and set INIT bit to OFF.

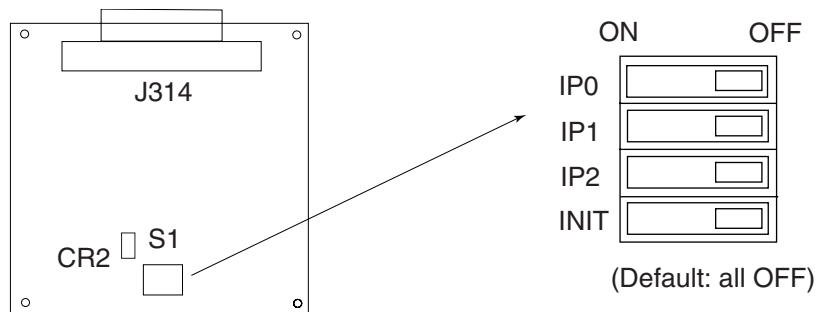

CARDCPU board 03P9333

Memory card interface unit, showing location of DIP switch S1

4.3 DVI-RGB Conversion Kit

This information provides the procedure necessary for the installation of the DVI-RGB conversion kit. This kit is installed in the processor unit to enable connection of an RGB monitor or VDR (Voyage Data Recorder).

Name: DVI-RGB conversion kit
 Type: OP03-180-2
 Code no.: 008-536-070

See packing list for contents. Refer to the figure below for modification.

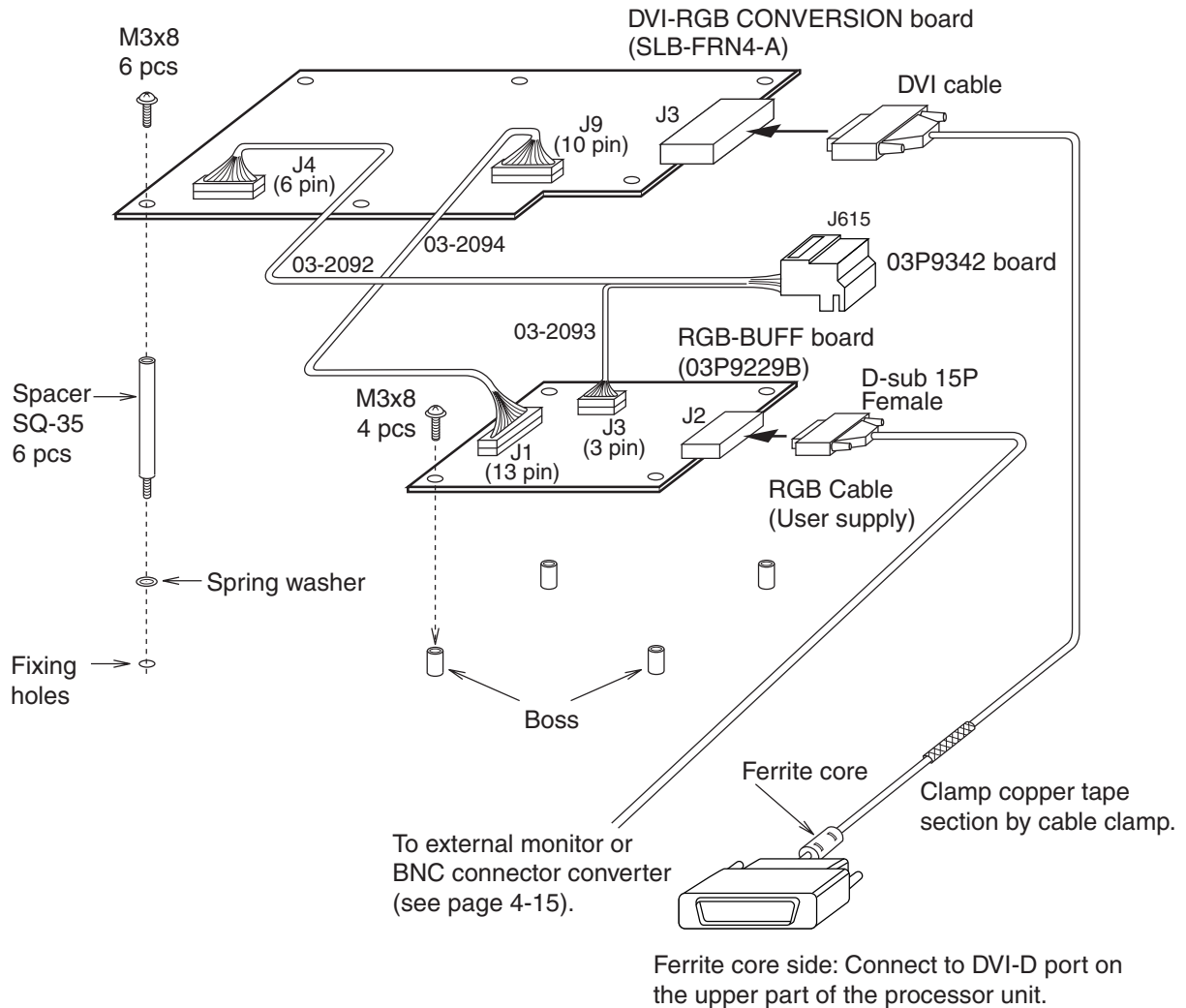

How to wire the DVI-RBG conversion board

1. Remove the top cover and open the upper part of the processor unit.

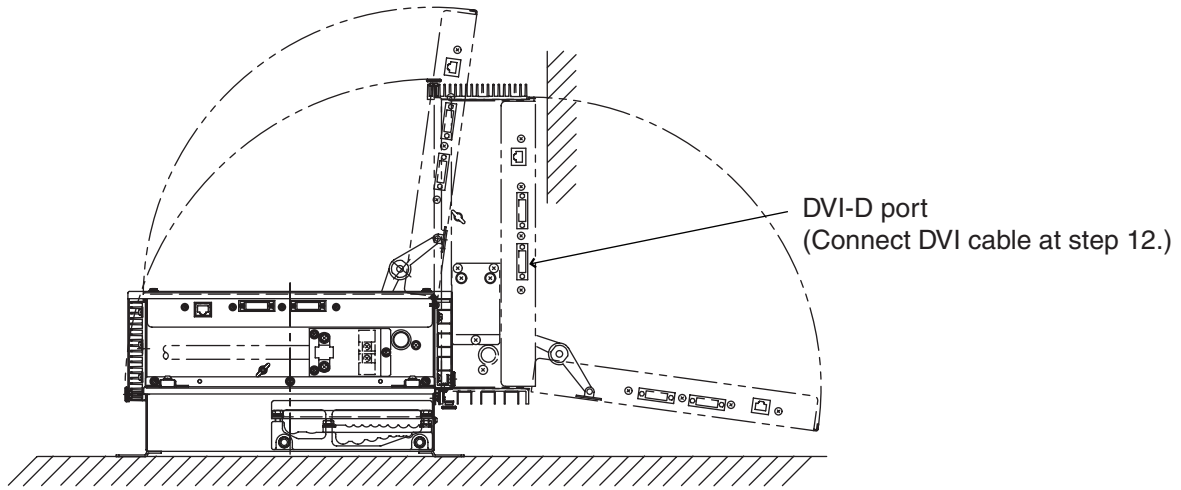

Processor unit, side view

2. Fix the RGB-BUFF board (03P9229B board) with four screws. (See the figure below.)

3. Attach the connector assemblies to J1 and J3 on the 03P9229B board as follows.

J1: 13-pin connector of the connector assembly 03-2094

J3: 3-pin connector of the connector assembly 03-2093

4. Attach six sets of spring washers and spacers at the locations shown below.

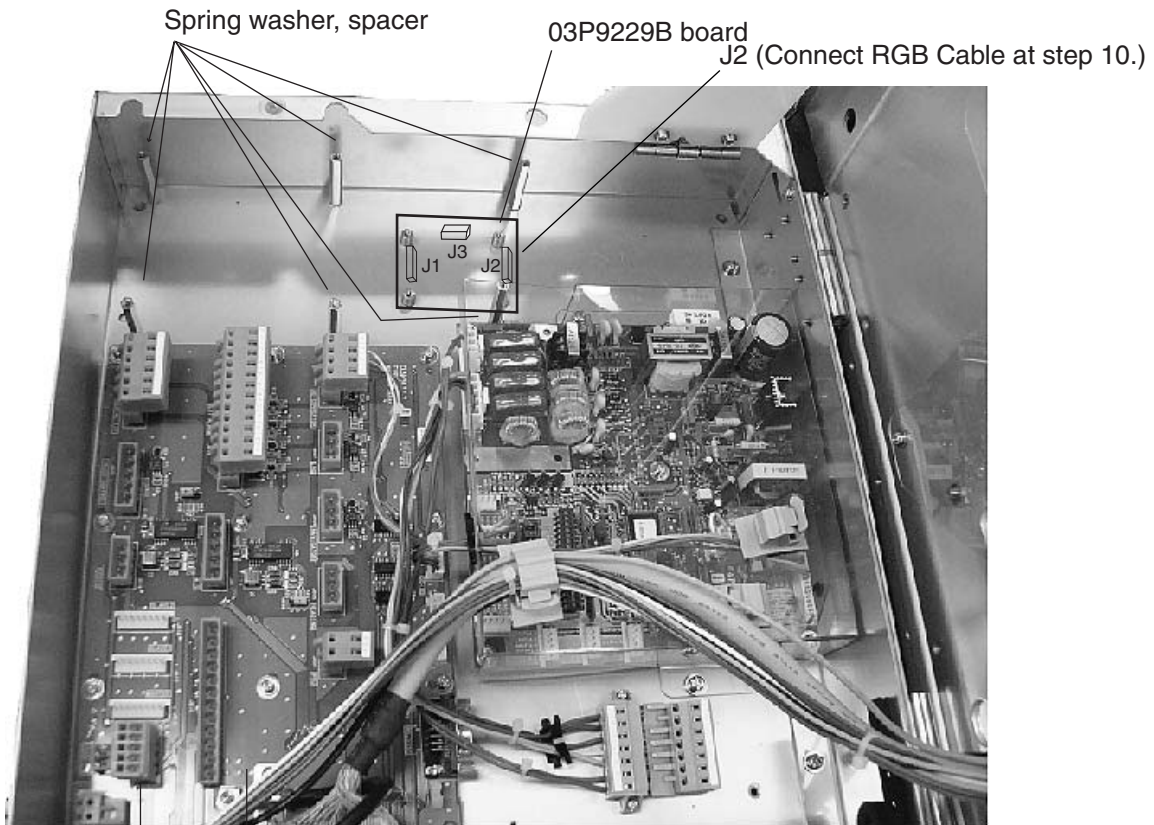

03P9342 board
J615 (Connect connector assemblies at step 8.)

Processor unit (bottom chassis)

5. Attach the DVI-RGB CONVERSION board to the location shown below.

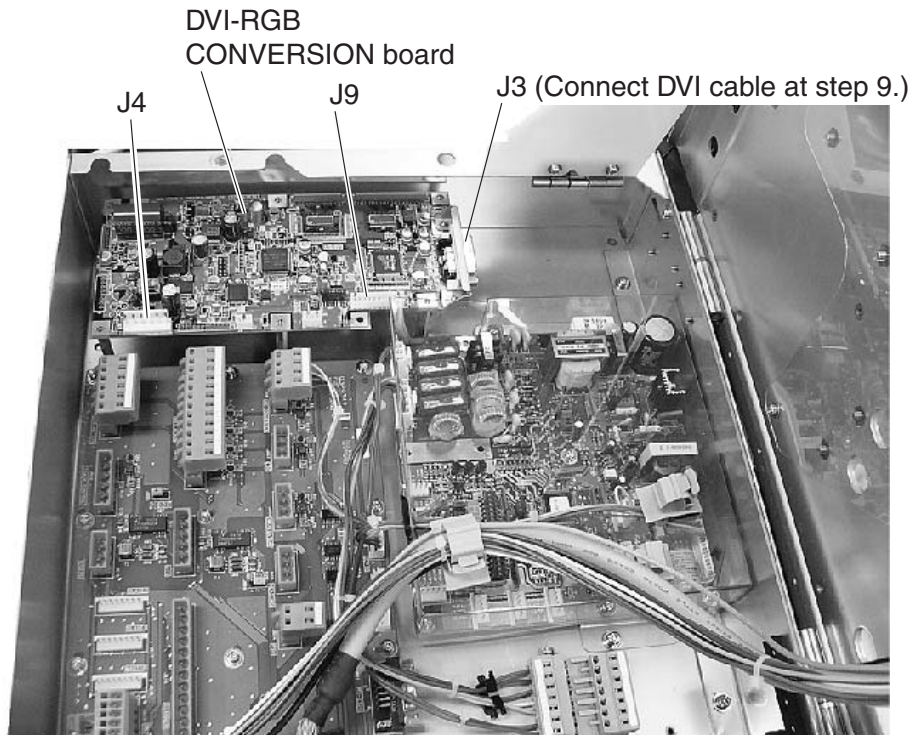

Fixing the DVI-RGB conversion board inside the processor unit

6. Attach the 10-pin connector from J1 on the 03P9229B board to J9 on the DVI-RGB board.
7. Attach the connector assembly 03-2092 to J4 on the DVI-RGB CONVERSION board.
8. Remove connector housing J615 from the 03P9342 board. Connect the cable from J3 on the 03P9229B board and the cable from J4 on the DVI-RGB CONVERSION board to J615. Attach J615 to the 03P9342 board.

To connect wires to the WAGO connector, use the terminal opener (supplied as installation materials) as shown below.

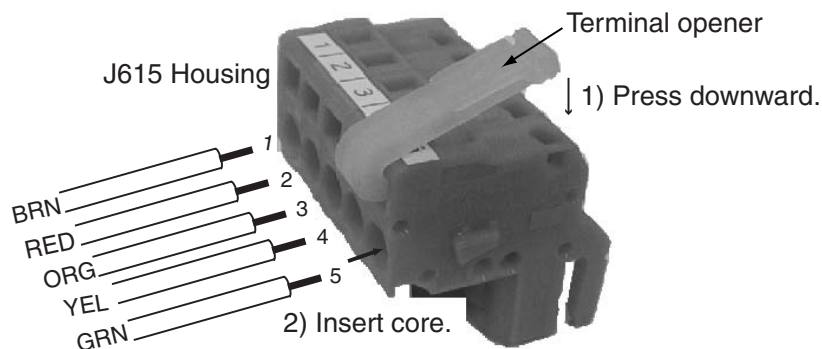

Connecting wires to the housing

9. Connect the DVI cable to J3 on the DVI-RGB CONVERSION board. Connect the end that does not have the ferrite core.
10. Pass an RGB cable (local supply) through the cable clamp and connect it to J2 on the 03P9229B board.
11. Pass the DVI cable through the cable clamp, laying the section with copper tape in the cable clamp.
12. Assemble the processor unit and connect the other end of the DVI cable to the DVI-D port.

4.4 BNC Connector Converter

To connect the FURUNO Voyage Data Recorder VR-5000 to this radar, the DVI-RGB conversion kit (mentioned at previous paragraph) and the BNC connector converter are required. Also VGA cable (between the processor unit and the BNC connector converter) and five 75 ohm coaxial cables (between the BNC connector converter and VR-5000) are required.

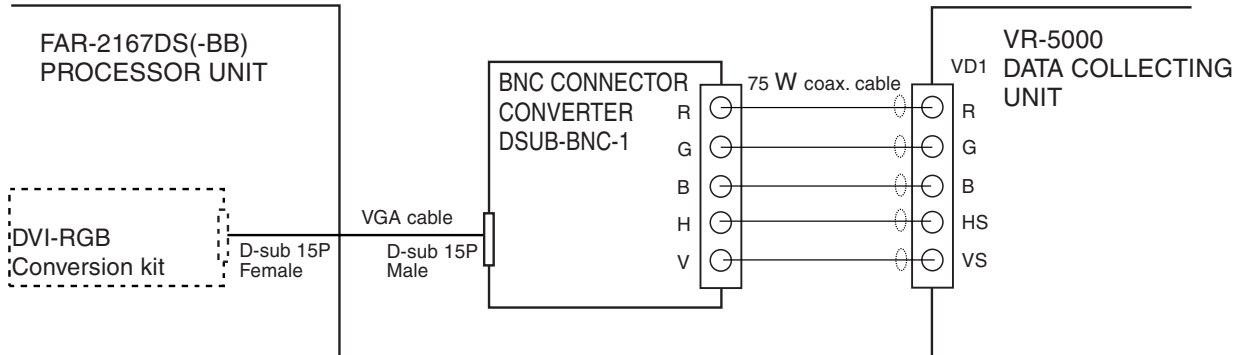

Connecting VR-5000 to FAR-2167DS(-BB) via BNC connector converter

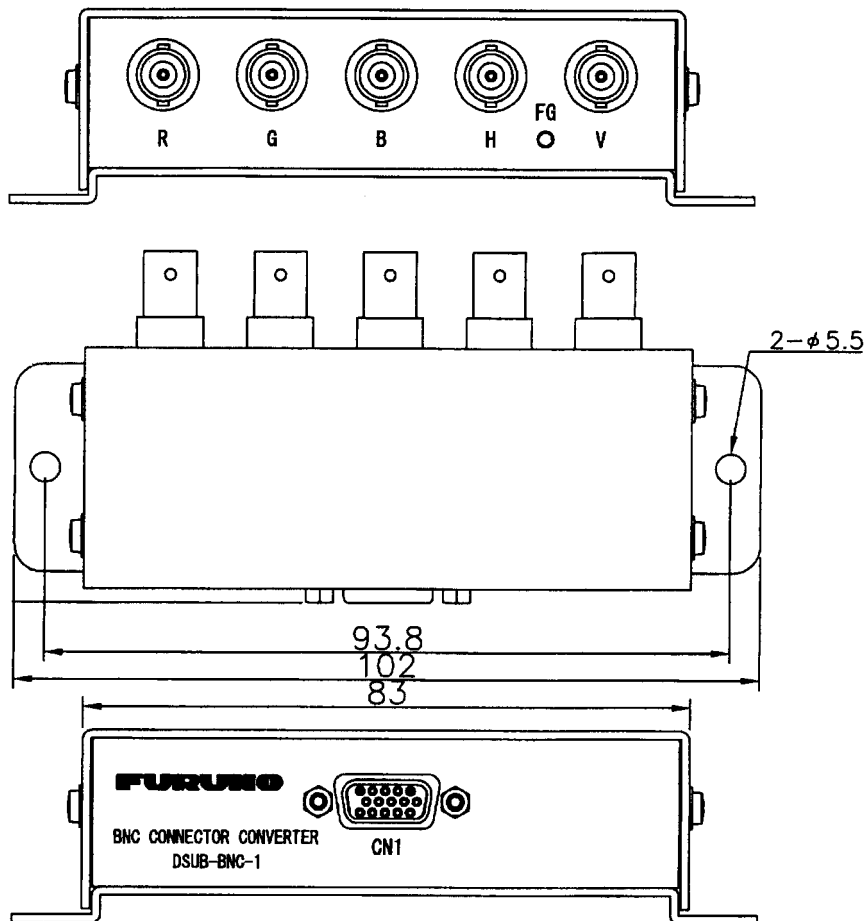

BNC connector converter

5. IO DATA

Available input and output data are shown in the tables below and input and output sentences are shown on the next page.

Note: This radar accepts position data fixed by WGS-84 geodetic datum only. Set the datum to WGS-84 on the EPFS (GPS, etc.) connected to this radar. If other type of datum is input, the error message "DATUM" appears and the AIS feature is inoperative.

Input

Data	Specifications	Contents	Remarks
Heading signal	Synchro or step	GC-10 required	Switching between AD-10 and IEC 61162 is done from menu.
	AD-10 format	External AD-100	
	IEC 61162-2		
Speed signal	IEC 61162-1		
Navigator data	IEC 61162-1	Position, course, speed, LORAN-C TD, waypoint, route, time, wind speed and direction, current data, depth, water temperature, roll, pitch, ROT	
External radar signal	Heading, Bearing, Trigger, Video	No GAIN, STC control	Operate as remote display
Alarm ACK input	Contact closure signal		Input signal from alarm system
Track Control unit	RS-422		Option

Output

Data	Specifications	Contents	Remarks
Radar system data	RS-232C	RSD, OSD, TLL	For PC plotter
ARPA data	IEC 61162-1	TTM	For ECDIS
Remote display signal	Heading, Bearing, Tx Trigger, Video		2 ports
External LCD monitor signal	DVI	Same as main monitor unit	2 systems max.
External CRT monitor signal	R, G, B, H, V	Same as main monitor unit	Option
Alarm signal	Contact closure signal	Output to alarm system by using photo-relay	4 outputs, output content selected from menu.

IEC 61162 input sentence and priority

Item	Sentence and order of priority
Speed (STW)	VBW>VHW
Speed (SOG)	VBW
Speed (position)	VTG>RMC
Heading (True)	HDT*
Position	GGA>GLL>RMC>RMABWR>BWC>RM
Waypoint	B
Date	ZDA
Depth	DPT>DBT>DBS
Water temperature	MTW
Wind	MWV

IEC 61162 output sentence



Item	Sentence
Target L/L	TLL (Not on IMO radar)
Radar system data	RSD
Own ship data	OSD
ARPA target data	TTM

HDT is IEC61162-2, all other sentences are IEC61162-1 ed2.

PACKING LIST

03GX-X-9853 -0 1/1 A-1

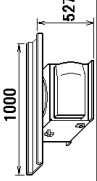
RSB-111-084-S/RSB-112-084-S

NAME	OUTLINE	DESCRIPTION/CODE No.	Q'TY
ユニット			
空中線本体部組品		RSB-111-084-S/RSB-112-084-S	1
付属品	ACCESSORIES		
付属品		FPO3-10101	1
付属品	000-090-687-00 **		
工事材料			
INSTALLATION MATERIALS			
工事材料		CP03-31501	1
工事材料	008-538-730-00		
工事材料	008-573-780-00		

コート番号末尾の「**」は、選用品の代表コードを表します。
CODE NUMBER ENDING WITH " **" INDICATES THE CODE NUMBER OF REPRESENTATIVE MATERIAL.







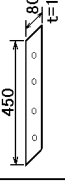

型式/コード番号が2段の場合、下段より上段に代わる通達部品であり、どちらが入っています。なお、品質は変わりません。
TWO TYPES AND CODES MAY BE LISTED FOR AN ITEM. THE LOWER PRODUCT MAY BE SHIPPED IN PLACE OF THE UPPER PRODUCT. QUALITY IS THE SAME.
(略図の寸法は、参考値です。 DIMENSIONS IN DRAWING FOR REFERENCE ONLY.)

03GX-X-9853

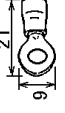
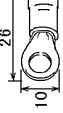
FURUNO

工事材料表

INSTALLATION MATERIALS

番号 NO.	名称 NAME	略図 OUTLINE	型名/規格 DESCRIPTIONS	数量 Q'TY	用途/備考 REMARKS
コード 008-573-780-00 03GX-X-9403 -1 タイプ CP03-31501 1/2					
1	シーロムワッシャー SEAL WASHER		03-001-3002-0 CODE NO. 300-130-020-00	8	
2	防蝕ゴム CORROSION-PROOF RUBBER MAT		03-029-0301-2 CODE NO. 100-091-112-00	2	
3	操作ハイ-ターミナルオープナー TERMINAL OPENER		Z31-131 CODE NO. 000-808-981-00	1	
4	圧着端子 CRIMP-ON LUG		FV2-4 7# CODE NO. 000-538-118-00	3	
5	圧着端子 CRIMP-ON LUG		FV5.5-4 CODE NO. 000-538-123-00	1	
6	Oリング O-RING		JBIAG-60 CODE NO. 000-851-309-00	2	
7	ハコ平盛金 SPRING WASHER		M12 SUS304 CODE NO. 000-864-263-00	8	
8	ハコ平盛金 FLAT WASHER		M12 SUS304 CODE NO. 000-864-132-00	8	
9	六角ナット 1種 HEX. NUT		M12 SUS304 CODE NO. 000-863-112-00	16	
10	六角ボルト (全彩) HEX. BOLT		M12X70 SUS304 M12X70 SUS304 CODE NO. 000-102-814-10 000-807-825-00	8	

型式/コード番号が2段の場合、下段より上段に代わる通達部品であり、どちらが入っています。なお、品質は変わりません。
TWO TYPES AND CODES MAY BE LISTED FOR AN ITEM. THE LOWER PRODUCT MAY BE SHIPPED IN PLACE OF THE UPPER PRODUCT. QUALITY IS THE SAME.
(略図の寸法は、参考値です。 DIMENSIONS IN DRAWING FOR REFERENCE ONLY.)



FURUNO ELECTRIC CO., LTD

03GX-X-9403

FURUNO

工事材料表

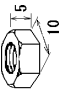
INSTALLATION MATERIALS

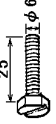
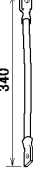

番号 NO.	名称 NAME	略図 OUTLINE	型名/規格 DESCRIPTIONS		数量 Q'TY	用途/備考 REMARKS
			型名/規格 DESCRIPTIONS	数量 Q'TY		
11	六角ナット HEX. NUT		M6 SUS304	1		
			CODE NO. 000-158-866-10			
12	ハネばね SPRING WASHER		M6 SUS304	1		
			CODE NO. 000-158-865-10			
13	動平座金 FLAT WASHER		M6 SUS304	3		
			CODE NO. 000-158-864-10			
14	六角ボルト HEX. BOLT		M6X25 SUS304	1		
			CODE NO. 000-162-871-10			
15	7-線 GROUNDING WIRE		RW-4747-1 03S4747-2	1		
			CODE NO. 1000-566-000-01			

型式/コード番号が2股の場合、下限より上段に代わる標準部品であり、どちらが入っています。なお、品質は変わりません。
TWO TYPES AND CODES MAY BE LISTED FOR AN ITEM. THE LOWER PRODUCT MAY BE SHIPPED IN PLACE OF THE UPPER PRODUCT.
QUALITY IS THE SAME.
(略図の寸法は、参考値です。 DIMENSIONS IN DRAWING FOR REFERENCE ONLY.)

FURUNO

付属品表

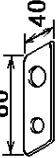
ACCESSORIES



番号 NO.	名称 NAME	略図 OUTLINE	型名/規格 DESCRIPTIONS		数量 Q'TY	用途/備考 REMARKS
			型名/規格 DESCRIPTIONS	数量 Q'TY		
1	つり上げ金具 LIFTING FIXTURE		03-015-3233-0	2		
			CODE NO. 100-090-720			
2	取付用拵 COLLAR FOR LIFTING FIXTURE		03-015-3234-0	2		
			CODE NO. 100-090-730			

CODE NO.	1008-538-730	0360-X-9501-0
TYPE	FP03-10101	

PACKING LIST

SN30AF/SN36AF

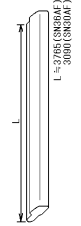
03FT-X-9851 -0 1/1

NAME		OUTLINE	DESCRIPTION/CODE No.	Q'TY
ユニット				
アンテナ組品	 <small>L=278(SN36AF) 300(SN30AF)</small>		SN30AF	1
ANTENNA			008-505-950 **	
アンテナ工材				
ANTENNA INSTALLATION MATERIALS				
工事材料			SN5AF/7AF/30AF/36AF	1
INSTALLATION MATERIALS			008-254-590	





1.コード番号末尾の[**]は、選択品の代表型式/コードを表します。
 CODE NUMBER ENDED BY "**" INDICATES THE NUMBER OF TYPICAL MATERIAL.

(略図の寸法は、参考値です。 DIMENSIONS IN DRAWING FOR REFERENCE ONLY.)
 03FT-X-9851

FURUNO

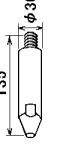
工事材料表

INSTALLATION MATERIALS

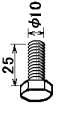
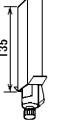

番号 NO.	名称 NAME	略図 OUTLINE	型名/規格 DESCRIPTIIONS		数量 Q'TY	用途/備考 REMARKS
			0 TY			
SN5AF/7AF/30AF/MSA/30AF/36AF						
1	ピン GUIDE PIN		03-006-4081-0	2		
2	Oリング O-RING		000-640-810	2		
3	フラット平座金 FLAT WASHER		000-851-309	10		
4	スプリング座金 SPRING WASHER		000-864-131	10		
5	六角ボルト HEX BOLT		000-868-778	10		
6	シリコンパッキン SILICON RUBBER		000-158-483	1		

(略図の寸法は、参考値です。 DIMENSIONS IN DRAWING FOR REFERENCE ONLY.)

FURUNO ELECTRIC CO., LTD.
 0300-X-9421

FURUNO

工事材料表

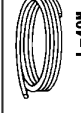
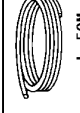



CODE NO.		03GL-X-9401-3		1/1	
TYPE					
FAR-2117series					
番号 NO.	名称 NAME	略図 OUTLINE	型名/規格 DESCRIPTIONS	数量 Q'TY	用途/備考 REMARKS
1	ケーブル(14C) CABLE	 L=15M	RW-9600 *15M*	1	選択 信号ケーブル TO BE SELECTED SIGNAL CABLE
			CODE NO. 000-147-370		
2	ケーブル(14C) CABLE	 L=30M	RW-9600 *30M*	1	選択 信号ケーブル TO BE SELECTED SIGNAL CABLE
			CODE NO. 000-149-193		
3	ケーブル(14C) CABLE	 L=40M	RW-9600 *40M*	1	選択 信号ケーブル TO BE SELECTED SIGNAL CABLE
			CODE NO. 000-150-490		
4	ケーブル(14C) CABLE	 L=50M	RW-9600 *50M*	1	選択 信号ケーブル TO BE SELECTED SIGNAL CABLE
			CODE NO. 000-147-373		

03GL-X-9401

FURUNO ELECTRIC CO., LTD.
(略図の寸法は、参考値です。 DIMENSIONS IN DRAWING FOR REFERENCE ONLY.)

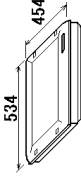
PACKING LIST

MU-201CR

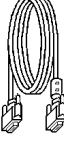
NAME		OUTLINE		DESCRIPTION/ CODE No.		Q'TY	
ユニット							
表示部 DISPLAY UNIT				MU-201CR		1	
予備品							
予備品				SP03-03900		1	
SPARE PARTS				000-080-288**		DC用	
予備品							
予備品				SP03-14401		1	
SPARE PARTS				008-535-990		AC用	
付属品							
付属品				FP03-09810		1	
ACCESSORIES				008-536-010			
その他工材							
ケーブル/組品				DVI-D/D SINGLELINK 5M		1	
CABLE ASSY.				000-149-054		L=5M	

1.コード末尾に[**]の付いたユニットは代表の型式/コードを表示しています。
DOUBLE ASTERISK DENOTES COMMONLY USED EQUIPMENT.
2.予備品は、AC用/DC用で選択願います。
CHOOSE SPARE PARTS DEPENDING ON AC OR DC POWER.

(略図の寸法は、参考値です。 DIMENSIONS IN DRAWING FOR REFERENCE ONLY.)
03GL-X-9855

FURUNO

CODE NO.	008-535-990	03GL-X-9303 -1	P
TYPE	SP03-14401	BOX NO.	

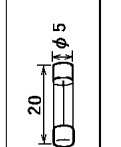
SHIP NO.	SPARE PARTS LIST FOR	U S E				REMARKS/CODE NO.
		DWG. NO. OR TYPE NO.	QUANTITY WORKING PER SET	QUANTITY SPARE PER VES	SETS PER VESSEL	
ITEM NO.	NAME OF PART	OUTLINE				
1	エー・X FUSE		FGMB 250V 2A PBF	2	表示部用 FOR DISPLAY UNIT 000-157-497-10 000-122-000-00	

MFR S NAME	FURUNO ELECTRIC CO., LTD.	DWG NO.	03GL-X-9303	1/1
------------	---------------------------	---------	-------------	-----

(略図の寸法は、参考値です。 DIMENSIONS IN DRAWING FOR REFERENCE ONLY.)
 型式/ユニット番号が2取の場合は、下図より上図に代わる過熱部品であり、どちらが入っています。 なお、品質は変わりません。
 TWO TYPES AND CODES MAY BE LISTED FOR AN ITEM. THE LOWER PRODUCT MAY BE SHIPPED IN PLACE OF THE UPPER PRODUCT. QUALITY IS THE SAME.

FURUNO

付属品表

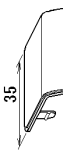
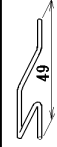
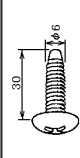

ACCESSORIES

番号 NO.	名称 NAME	略 図 OUTLINE	型名/規格 DESCRIPTIONS		数量 QTY	用途/備考 REMARKS
			CODE NO.	100-305-111		
1	化粧カバー COSMETIC CAP		03-163-1101-1		4	表示部用 FOR DISPLAY UNIT
2	化粧フック PANEL HOOK		03-163-1102-0		2	表示部用 FOR DISPLAY UNIT
3	+selfタッピングねじ 1種 SELF-TAPPING SCREW		6X30 SUS304		4	表示部用 FOR DISPLAY UNIT

03GL-X-9504

(略図の寸法は、参考値です。 DIMENSIONS IN DRAWING FOR REFERENCE ONLY.)
 FURUNO ELECTRIC CO., LTD.

FURUNO

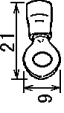
CODE NO.		008-535-940		03GL-X-9405-0	
TYPE		CP03-25602		1/1	
AC用					
工事材料表					
INSTALLATION MATERIALS					
番号 NO.	名称 NAME	略図 OUTLINE	型名/規格 DESCRIPTIONS	数量 Q'TY	用途/備考 REMARKS
1	操作爪 - TERMINAL OPENER		231-131	1	制御部用 FOR PROCESSOR UNIT
2	操作爪 - TERMINAL OPENER		734-230	1	制御部用 FOR PROCESSOR UNIT
3	圧着端子 CRIMP-ON LUG		FV2-477 CODE NO. 000-538-118	2	制御部用 FOR PROCESSOR UNIT

03GL-X-9405

FURUNO ELECTRIC CO., LTD.
DIMENSIONS IN DRAWING FOR REFERENCE ONLY.)

(略図の寸法は、参考値です。)





型式/コト番号が2段の場合、下段より上段に代わる適量部品であり、どちらが入りか入らないかを、なお、品質は変わりません。
TWO TYPES AND CODES MAY BE LISTED FOR AN ITEM. THE LOWER PRODUCT MAY BE SHIPPED IN PLACE OF THE UPPER PRODUCT. QUALITY IS THE SAME.





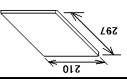
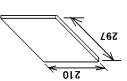
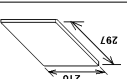

3(*3) FAR-2157/2167DS仕様の時のみ添付されます。
SUPPLIED WITH FAR-2157/2167DS ONLY.

1 コト番号末尾の[**]は、選択品の代表コードを表します。
CODE NUMBER ENDING WITH "**" INDICATES THE CODE NUMBER OF REPRESENTATIVE MATERIAL.

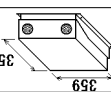
2 (*1) (*2) は、それぞれ仕様選択品を表します。
(*1) (*2) INDICATE SPECIFICATION SELECTIVE ITEM.

(略図の寸法は、参考値です。DIMENSIONS IN DRAWING FOR REFERENCE ONLY.)

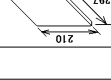
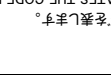
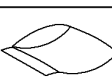
NAME	OUTLINE	DESCRIPTION/CODE No.	Q'TY
取扱説明書		OM*-35221-*	1
取扱説明書		000-164-255-0*	(*3)
装束類領書		IM*-35***-*	1
装束類領書		000-147-454-0*	**
取扱説明書		OS*-35190-*	1
取扱説明書		000-153-046-0*	**

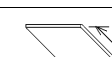
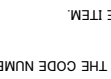
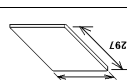
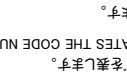
NAME	OUTLINE	DESCRIPTION/CODE No.	Q'TY
制御部		RPJ-013*	1
制御部		000-081-381-00	**
予備品		SP03-14404	1
予備品		008-535-910-00	(*1)
予備品		SP03-14405	1
予備品		008-535-920-00	(*1)
予備品		SP03-14406	1
予備品		008-535-930-00	(*1)
工事材料		GP03-25602	1
工事材料		008-535-940-00	(*2)
工事材料		GP03-25603	1
工事材料		008-535-950-00	(*2)
取扱説明書		OM*-35190-*	1
取扱説明書		000-147-452-0*	**

PACKING LIST RPJ-013

FURUNO

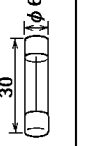
SHIP NO.		SPARE PARTS LIST FOR		U S E		CODE NO. TYPE	008-535-910 SP03-14404	03GL-X-9305 -1 1/1	BOX NO. P	SETS PER VESSEL		
ITEM NO.	NAME OF PART	OUTLINE	DWG. NO. OR TYPE NO.	QUANTITY		REMARKS/CODE NO.						
				WORKING PER SET	SPARE							
1	E ₃ -X ¹ FUSE		FB00-125V 10A PBF		4	AC100用 FOR PROCESSOR UNIT 000-155-826-10						
MFR'S NAME			FURUNO ELECTRIC CO., LTD.			DWG NO.		03GL-X-9305			1/1	

(附図の寸法は、参考値です。 DIMENSIONS IN DRAWING FOR REFERENCE ONLY.)
 型式/コード番号が2取の場合、下図より上図に代わる通称部品であり、どちらが入っています。 なお、品質は変わりません。
 TWO TYPES AND CODES MAY BE LISTED FOR AN ITEM. THE LOWER PRODUCT MAY BE SHIPPED IN PLACE OF THE UPPER PRODUCT. QUALITY IS THE SAME.



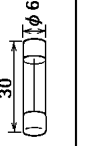

FURUNO

SHIP NO.		SPARE PARTS LIST FOR		U S E		CODE NO. TYPE	008-535-920-00 SP03-14405	03GL-X-9306 -1 1/1	BOX NO. P	SETS PER VESSEL		
ITEM NO.	NAME OF PART	OUTLINE	DWG. NO. OR TYPE NO.	QUANTITY		REMARKS/CODE NO.						
				WORKING PER SET	SPARE							
1	E ₃ -X ¹ FUSE		FB00-250V 5A PBF		4	AC220用 FOR PROCESSOR UNIT 000-155-840-10						
MFR'S NAME			FURUNO ELECTRIC CO., LTD.			DWG NO.		03GL-X-9306			1/1	

(附図の寸法は、参考値です。 DIMENSIONS IN DRAWING FOR REFERENCE ONLY.)
 型式/コード番号が2取の場合、下図より上図に代わる通称部品であり、どちらが入っています。 なお、品質は変わりません。
 TWO TYPES AND CODES MAY BE LISTED FOR AN ITEM. THE LOWER PRODUCT MAY BE SHIPPED IN PLACE OF THE UPPER PRODUCT. QUALITY IS THE SAME.

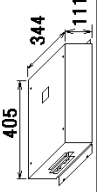
PACKING LIST

PSU-006

NAME	OUTLINE	DESCRIPTION/CODE No.	QTY
UNIT			
ユニット 電源制御部 POWER CONTROL UNIT		PSU-006-*** 000-090-665-00 **	1
SPARE PARTS			
予備品 SPARE PARTS		SP03-15501 008-572-730-00	1 (*1)
予備品 SPARE PARTS		SP03-15502 008-572-740-00	1 (*1)
工事材料			
工事材料 INSTALLATION MATERIALS		CP03-31401 008-572-750-00	1

(*)の予備品は仕様によりAC100用:SP03-15501,AC220用:SP03-15502.
*1. SELECT ONE ACCORDING TO PROCESSOR UNIT'S SPECIFICATIONS : SP03-15501 FOR 100VAC OR SP03-15502 FOR 220VAC

型式/コード番号が2段の場合、下段より上段に代わる過渡部品であり、どちらが入っています。なお、品質は変わりません。
TWO TYPES AND CODES MAY BE LISTED FOR AN ITEM. THE LOWER PRODUCT MAY BE SHIPPED IN PLACE OF THE UPPER PRODUCT. QUALITY IS THE SAME.
(略図の寸法は、参考値です。 DIMENSIONS IN DRAWING FOR REFERENCE ONLY.)

FURUNO

工事材料表

INSTALLATION MATERIALS

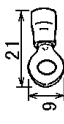
番号 NO.	名称 NAME	略図 OUTLINE	型名/規格 DESCRIPTIONS	数量 QTY	用途/備考 REMARKS
1	圧着端子 CRIMP-ON LUG		FV2-4 74 CODE NO. 000-538-118-00	14	

型式/コード番号が2段の場合、下段より上段に代わる過渡部品であり、どちらが入っています。なお、品質は変わりません。
TWO TYPES AND CODES MAY BE LISTED FOR AN ITEM. THE LOWER PRODUCT MAY BE SHIPPED IN PLACE OF THE UPPER PRODUCT. QUALITY IS THE SAME.
(略図の寸法は、参考値です。 DIMENSIONS IN DRAWING FOR REFERENCE ONLY.)

FURUNO

CODE NO. 008-572-740-00 030X-X-9302-0 1/1
 TYPE SP03-15502 BOX NO. P

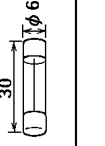
SHIP NO.	SPARE PARTS LIST FOR	U S E		REMARKS/CODE NO.	
		POWER CONTROL UNIT	SETS PER VESSEL		
	AC220V				
ITEM NO.	NAME OF PART	OUTLINE	DWG. NO. OR TYPE NO.	QUANTITY	
				WORKING PER SET	SPARE
1	1.5-A FUSE		FCB0-250V 3A PBF		2

MFR S NAME FURUNO ELECTRIC CO., LTD. DWG NO. 030X-X-9302 1/1

(船図の寸法は、参考値です。 DIMENSIONS IN DRAWING FOR REFERENCE ONLY.)
 型式/コード番号が2取の場合、下取より上取に代わる選定期品であり、どちらが入っています。 なお、品質は最
 上りません。
 TWO TYPES AND CODES MAY BE LISTED FOR AN ITEM. THE LOWER PRODUCT MAY BE SHIPPED IN PLACE OF THE
 UPPER PRODUCT. QUALITY IS THE SAME.

FURUNO

CODE NO. 008-572-730-00 030X-X-9301-0 1/1
 TYPE SP03-15501 BOX NO. P

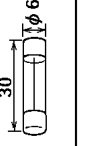
SHIP NO.	SPARE PARTS LIST FOR	U S E		REMARKS/CODE NO.	
		POWER CONTROL UNIT	SETS PER VESSEL		
	AC100V				
ITEM NO.	NAME OF PART	OUTLINE	DWG. NO. OR TYPE NO.	QUANTITY	
				WORKING PER SET	SPARE
1	1.5-A FUSE		FCB0-250V 5A PBF		2

MFR S NAME FURUNO ELECTRIC CO., LTD. DWG NO. 030X-X-9301 1/1

(船図の寸法は、参考値です。 DIMENSIONS IN DRAWING FOR REFERENCE ONLY.)
 型式/コード番号が2取の場合、下取より上取に代わる選定期品であり、どちらが入っています。 なお、品質は最
 上りません。
 TWO TYPES AND CODES MAY BE LISTED FOR AN ITEM. THE LOWER PRODUCT MAY BE SHIPPED IN PLACE OF THE
 UPPER PRODUCT. QUALITY IS THE SAME.

FURUNO

CODE NO.	008-539-850	03GL-X-9411 -0	1/1
TYPE	CP03-25604		

工事材料表

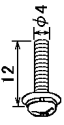
番号 NO.	名称 NAME	略図 OUTLINE	型名/規格 DESCRIPTIONS	数量 Q'TY	用途/備考 REMARKS
1	ワッシャー WASHER HEAD SCREW		MAX12 C270W MBN12 CODE NO. 000-881-447	4	

03GL-X-9411

FURUNO ELECTRIC CO., LTD.
DIMENSIONS IN DRAWING FOR REFERENCE ONLY.)

FURUNO

CODE NO.	008-535-610	03GL-X-9505 -3	1/1
TYPE	FP03-09850		

付属品表

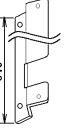
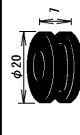
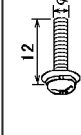
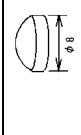
番号 NO.	名称 NAME	略図 OUTLINE	型名/規格 DESCRIPTIONS	数量 Q'TY	用途/備考 REMARKS
1	KB直付金具 KB FIXING METAL		03-163-7521-1 CODE NO. 100-306-251	1	操作部用 FOR CONTROL UNIT
2	ゴムパット GROMMET		G-39 CODE NO. 000-147-167	1	操作部用 FOR CONTROL UNIT
3	ワッシャー WASHER HEAD SCREW		MAX12 C270W MBN12 CODE NO. 000-881-447	2	操作部用 FOR CONTROL UNIT
4	クッション CUSHION		TM-180-302 CODE NO. 000-803-043	3	操作部用 FOR CONTROL UNIT



03GL-X-9505

FURUNO ELECTRIC CO., LTD.
DIMENSIONS IN DRAWING FOR REFERENCE ONLY.)

FURUNO

CODE NO.	008-535-690	03GL-X-9506-3	1/1
TYPE	FP03-09880		

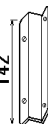
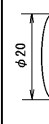
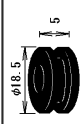
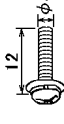
付属品表

番号 NO.	名称 NAME	略図 OUTLINE	型名/規格 DESCRIPTIONS	数量 Q'TY	用途/備考 REMARKS
1	KB直付金具 (T) KB FIXING METAL	 142	03-163-7821-1 CODE NO. 100-306-291	1	操作部用 FOR CONTROL UNIT
2	アラウンドシール SEAL	 $\phi 20$	22-020-1005-1 CODE NO. 100-173-591	3	操作部用 FOR CONTROL UNIT
3	グロメット GROMMET	 $\phi 18.5$ 5	G-49 CODE NO. 000-871-309	1	操作部用 FOR CONTROL UNIT
4	ナナハ 皿洗ネジ B WASHER HEAD SCREW	 12 $\phi 4$	MAX12 C2700W MBN12 CODE NO. 000-881-447	2	操作部用 FOR CONTROL UNIT
5	クッションボーン CUSHION	 $\phi 8$	TM-180-302 CODE NO. 000-803-043	2	操作部用 FOR CONTROL UNIT

03GL-X-9506



(略図の寸法は、参考値です。 DIMENSIONS IN DRAWING FOR REFERENCE ONLY.)

FURUNO ELECTRIC CO., LTD.

FURUNO

CODE NO.	008-535-630	03GL-X-9503-2	1/1
TYPE	FP03-09870		

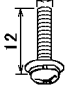
付属品表

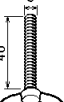
For RCU-014/015/016 Flush mount kit					
番号 NO.	名称 NAME	略図 OUTLINE	型名/規格 DESCRIPTIONS	数量 Q'TY	用途/備考 REMARKS
1	7ツツボ付金属具 FLUSH MOUNTING PLATE	 31	03-163-7531-1 CODE NO. 100-306-261	4	
2	ナナハ 皿洗ネジ B WASHER HEAD SCREW	 12 $\phi 4$	MAX12 C2700W MBN12 CODE NO. 000-881-447	4	
3	六角ナット 1種 HEX. NUT	 9 $\phi 4$	M5 SUS304 CODE NO. 000-863-108	4	
4	蝶ネジ WING SCREW	 40 $\phi 5$	M5X40 SUS304 CODE NO. 000-149-997	4	

03GL-X-9503







(略図の寸法は、参考値です。 DIMENSIONS IN DRAWING FOR REFERENCE ONLY.)

FURUNO ELECTRIC CO., LTD.

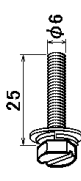
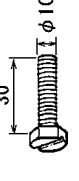
PACKING LIST

FP03-09820/09830 For MU-201CR/231CR Desktop mount kit Option

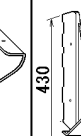
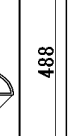
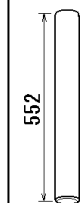
03GL-X-9859 -0 1/1

NAME	OUTLINE	DESCRIPTION/CODE No.	Q'TY
付属品 ACCESSORIES			
六角ボルト 2列用 HEX. BOLT (SLOTTED, WASHER HEAD)		M6X25 SUS304	4
六角ボルト 2列用 HEX. BOLT		000-802-771 M10X30 SUS304	2
ハネ座金 SPRING WASHER		000-802-182 M10 SUS304	2
ミカネ平座金 FLAT WASHER		000-864-261 M10 SUS304	2
スチールボルト PLASTIC RIVET		000-864-131 KB-133φ 12	4
ホールの栓 HOLE PLUG		000-570-276 CP-30-HP-13	2
ハンガー HANGER R		000-147-143 03-163-1112-0	1
ハンガー HANGER L		100-305-180 03-163-1111-0	1
ハンガー HANGER STAY		100-305-140 03-163-1113-0	1 (*1)
ハンガー HANGER STAY		100-305-190 03-163-2071-0	1 (*2)

(*1)は、FP03-09820用です。

*1: FOR FP03-09820

(*2)は、FP03-09830用です。





*2: FOR FP03-09830

(略図の寸法は、参考値です。 DIMENSIONS IN DRAWING FOR REFERENCE ONLY.)

03GL-X-9859

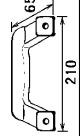
FURUNO

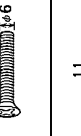
付属品表

ACCESSORIES	For MU-201CR/MU-231CR	CODE NO.	008-535-570	03GL-X-9502 -0
番号	名称	略図	型名/規格	数量
NO.	NAME	OUTLINE	DESCRIPTIONS	Q'TY
1	取手 HANDLE		14-002-1125-2 CODE NO. 840-211-252	2
2	円形ボルト座金 ROSETTE WASHER		M6 C2700W ホリゾンタル 丸 CODE NO. 000-864-910	4
3	丸皿小ネジ OVAL COUNTERSUNK HEAD SCREW		M6X20 C2700W ホリゾンタル 丸 CODE NO. 000-861-475	4
4	波座金 WAVE WASHER		WV-6 SUS CODE NO. 000-864-350	4





(略図の寸法は、参考値です。 DIMENSIONS IN DRAWING FOR REFERENCE ONLY.)

FURUNO ELECTRIC CO., LTD.

03GL-X-9502

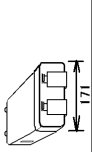
PACKING LIST





CU-200-FAR

NAME	OUTLINE	DESCRIPTION/CODE No.	QTY
ユニット			
メモリカードインターフェイス MEMORY CARD INTERFACE		CU-200 000-081-569-00	1
工事材料			
工事材料 INSTALLATION MATERIALS		CP03-27431 008-544-400-00	1
その他工材			
ケーブル組品 CABLE ASSY.		P5E-4PTX-BL 000-147-510-00	1
ケーブル組品MJ CABLE ASSY.		MJ-AS3PF0015-100C 000-156-054-11	1

FURUNO

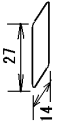
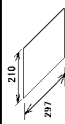
工事材料表

INSTALLATION MATERIALS

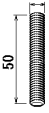
番号 NO.	名称 NAME	略図 OUTLINE	型名/規格 DESCRIPTIONS	数量 QTY	用途/備考 REMARKS
1	舵輪貼りマーク(BSH) STEERING WHEEL LABEL		03-801-0851-3 CODE NO. 100-277-723	1	
2	舵輪マーク貼付要領 LABEL ATTACHING PROCEDURE		C32-00407-* 7/14 CODE NO. 000-150-918	1	
3	ハコばね SPRING WASHER		M4 SUS304 CODE NO. 000-864-256	4	
4	フラットばね FLAT WASHER		M4 SUS304 CODE NO. 000-864-126	4	
5	六角ナット 一種 HEX NUT		M4 SUS304 CODE NO. 000-863-106	4	
6	寸切棒 THREADED ROD		M4X50 SUS304 CODE NO. 000-147-539	4	

0360-X-9404

FURUNO ELECTRIC CO., LTD.
(略図の寸法は、参考値です。 DIMENSIONS IN DRAWING FOR REFERENCE ONLY.)

型式コード番号が2段の場合、下段より上段に代わる過渡期品であり、どちらが入っています。なお、品質は変わりません。
TWO TYPES AND CODES MAY BE LISTED FOR AN ITEM. THE LOWER PRODUCT MAY BE SHIPPED IN PLACE OF THE UPPER PRODUCT. QUALITY IS THE SAME.
(略図の寸法は、参考値です。 DIMENSIONS IN DRAWING FOR REFERENCE ONLY.)

0360-X-9855



CODE NO. 008-539-530 0360-X-9502-0
 TYPE FP03-10201 1/1

付属品表

For CU-200 Desktop mount kit

番号 NO.	名称 NAME	略図 OUTLINE	型名/規格 DESCRIPTIONS	数量 Q'TY	用途/備考 REMARKS
1	マウンティングブラケット MOUNTING BRACKET		19-023-3081-0 CODE NO. 100-316-250	1	
2	タップネジ +TAPPING SCREW		5X20 SUS304 1/2 CODE NO. 000-802-081	4	
3	ワッシャー +ワッシャー A WASHER HEAD SCREW		MAX10 C2700W MBN12 CODE NO. 000-881-145	4	

Option

0360-X-9502

FURUNO ELECTRIC CO., LTD.
 DIMENSIONS IN DRAWING FOR REFERENCE ONLY.)

(略図の寸法は、参考値です。

PACKING LIST GC-10-2

NAME	OUTLINE	DESCRIPTION/ CODE No. Q'TY
------	---------	----------------------------

予備品 SPARE PARTS		SP03-13300 1
予備品 SPARE PARTS		008-419-280 1

その他部品 OTHER PARTS

NHケーブル NH CONNECTOR ASSY.		03-2091 (SP) 1 008-534-670 1
WHケーブル WH CONNECTOR ASSY.		03-2090 (3P) 1 008-534-660 1
XHケーブル XH-PH CONNECTOR ASSY.		03-2088 (6-14P) 1 008-534-640 1
演算ユニット PROCESSOR BOARD		64P1106A 1 004-412-220 1
ケーブル (231) CONNECTOR		231-607/019-FUR 1 000-147-414 1
ケーブル (231) CONNECTOR		231-107/026-FUR 1 000-147-413 1

NAME	OUTLINE	DESCRIPTION/ CODE No. Q'TY
ワッシャー A +ワッシャー A WASHER HEAD SCREW		MAX10 C2700W MBN12 2 000-801-844 2
ワッシャー B +ワッシャー B WASHER HEAD SCREW		MAX8 C2700W MBN12 5 000-881-404 5
GCカバー GC COVER ASSY.		GCカバー-組品 1 008-537-030 1

0360-X-9852-2 1/1

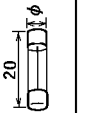

(略図の寸法は、参考値です。 DIMENSIONS IN DRAWING FOR REFERENCE ONLY.)

FURUNO

SHIP NO.	SPARE PARTS LIST FOR	U S E		REMARKS/CODE NO.			
		CODE NO. TYPE	BOX NO. P				
		008-419-280-00 SP03-13300	03GL-X-9302-2 P				
				SETS PER VESSEL 1/1			
	G-C-10						
ITEM NO.	NAME OF PART	OUTLINE	DWG. NO. OR TYPE NO.	QUANTITY	REMARKS/CODE NO.		
1	E ₁ -X ¹ FUZE		FGMB 250V 2A PBF FOMB 2A 250V	WORKING PER SET SPARE 8	000-157-497-10 000-122-000-00		
MFR'S NAME				FURUNO ELECTRIC CO., LTD.	DWG NO.	03GL-X-9302	1/1

(略図の寸法は、参考値です。 DIMENSIONS IN DRAWING FOR REFERENCE ONLY.)
 型式/コード番号が2段の場合、下段より上段に代わる速達部品であり、どちらが入っています。 なお、品質は変わりません。
 TWO TYPES AND CODES MAY BE LISTED FOR AN ITEM. THE LOWER PRODUCT MAY BE SHIPPED IN PLACE OF THE UPPER PRODUCT. QUALITY IS THE SAME.

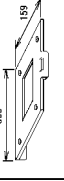
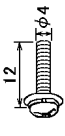
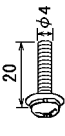
FURUNO

CODE NO. TYPE	008-535-640 OP03-183		03GL-X-9408-3 1/1		
	工事材料表 Coupling pedestal kit RCU-014 + MU-201CR				
INSTALLATION MATERIALS					
番号 NO.	名称 NAME	略図 OUTLINE	型名/規格 DESCRIPTIONS	数量 QTY	用途/備考 REMARKS
1	連結金具B COUPLING FIXTURE		03-163-7604-0 CODE NO. 100-308-270	1	RCU-014, MU-201CR用 FOR RCU-014 AND MU-201CR
2	ナット、ワッシャー NUT, WASHER		MAX12 G2700W MENV2 CODE NO. 000-881-447	4	RCU-014, MU-201CR用 FOR RCU-014 AND MU-201CR
3	ナット、ワッシャー NUT, WASHER		MAX20 G2700W MENV2 CODE NO. 000-881-451	2	RCU-014, MU-201CR用 FOR RCU-014 AND MU-201CR
4	連結台(20)組品 COUPLING PLATE ASSY.		OP03-183-1 CODE NO. 008-536-980	1	RCU-014, MU-201CR用 FOR RCU-014 AND MU-201CR

(略図の寸法は、参考値です。 DIMENSIONS IN DRAWING FOR REFERENCE ONLY.)

FURUNO

工事材料表

INSTALLATION MATERIALS

For LAN cable kit

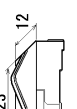







番号 NO.	名称 NAME	略図 OUTLINE	型名/規格 DESCRIPTIONS	数量 QTY	CODE NO.	用途/備考 REMARKS
					CP03-28901	
1	3芯用 (EJ-17) MODULAR CONNECTOR	23 	MPS588-C	2	03GL-X-9407-3	Option

PACKING LIST

DVI-RGB conversion kit

Option

OP03-180-2

NAME	OUTLINE	DESCRIPTION/CODE No.	QTY
その他部品 その他の部品	OTHER PARTS		
ワッシャー WASHER HEAD SCREW		M3X8 C2700W MBN12 000-881-404-00	10
DVI-RGB組品		SLB-FRM4-A 008-537-660-00	1
DVI-RGB ASSY.			
RGB-BUFFER リット		03P9229B 008-514-980-00	1
RGB-BUFF BOARD			
VH組品		03-2092 (6P) 008-534-690-00	1
VH CONNECTOR ASSY.			
XH組品		03-2093 (3P) 008-534-700-00	1
XH CONNECTOR ASSY.			
XH組品		03-2094 (13-10P) 008-534-710-00	1
XH CONNECTOR ASSY.			
ケーブル組品		DVI-D/D S-LINK 0.85M 000-148-644-00	1
CABLE ASSY.			
スパーサー		SQ-35 000-159-310-10 000-801-651-00	6
SPACER			
バネワッシャー		M3 C5191W MBN12 000-864-204-00	6
SPRING WASHER			

型式コード番号が空段の場合、下段より上段に代わる過渡期品であり、どちらが入っています。なお、品質は変わりません。
TWO TYPES AND CODES MAY BE LISTED FOR AN ITEM. THE LOWER PRODUCT MAY BE SHIPPED IN PLACE OF THE UPPER PRODUCT. QUALITY IS THE SAME.
(略図の寸法は、参考値です。DIMENSIONS IN DRAWING FOR REFERENCE ONLY.)

表 2 TABLE 2

7ソテナ型式 ANT. TYPE	SN36AF	SN30AF
A : 空中線長 ANT. LENGTH	3765±10mm	3090±10mm
B : 回転安全空間 ANT. CLEARANCE	3860mm	3200mm
質量 MASS	145kg±10%	137kg±10%



表 1 TABLE 1 固定脚寸法 FIXING LEG DIMENSIONS

寸法区分 (mm) DIMENSIONS	公差 (mm) TOLERANCE
L ≤ 50	± 1.5
50 < L ≤ 100	± 2.5
100 < L ≤ 500	± 3
500 < L ≤ 1000	± 4
1000 < L ≤ 2000	± 5
2000 < L ≤ 4000	± 7

注記 1) #印寸法は最小サービス空間寸法とする。
 2) 指定外の寸法公差は表1による。
 3) 取付用ネジはM12ボルトを使用のこと。

NOTE 1. # MINIMUM SERVICE CLEARANCE.
 2. TABLE 1 INDICATES TOLERANCE OF DIMENSIONS WHICH IS NOT SPECIFIED.
 3. USE M12 BOLTS FOR FIXING THE UNIT.

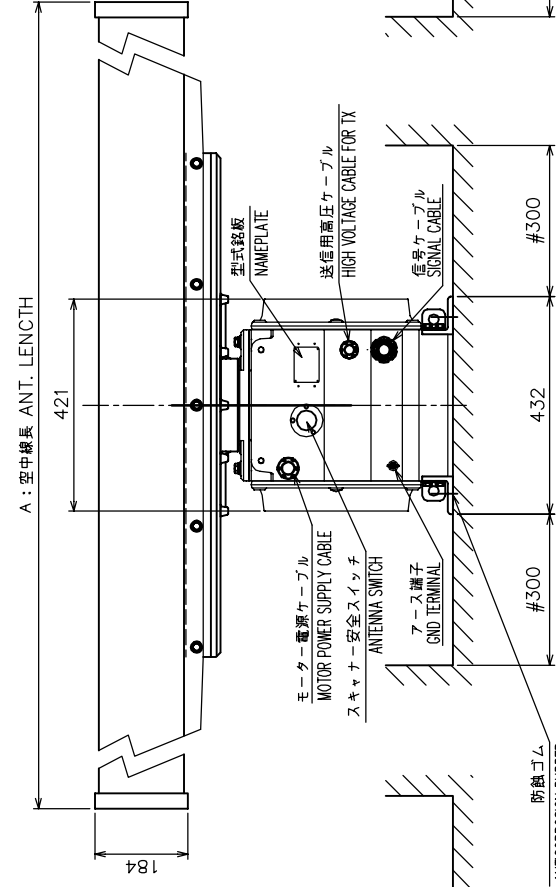
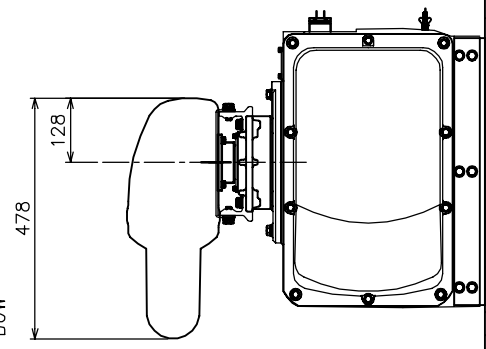
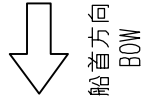
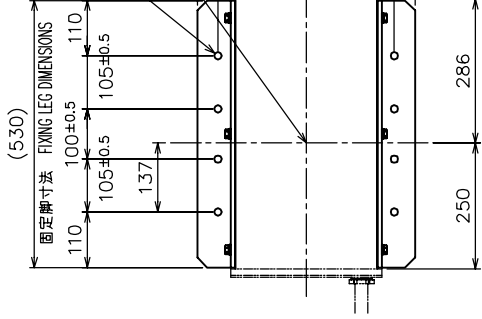
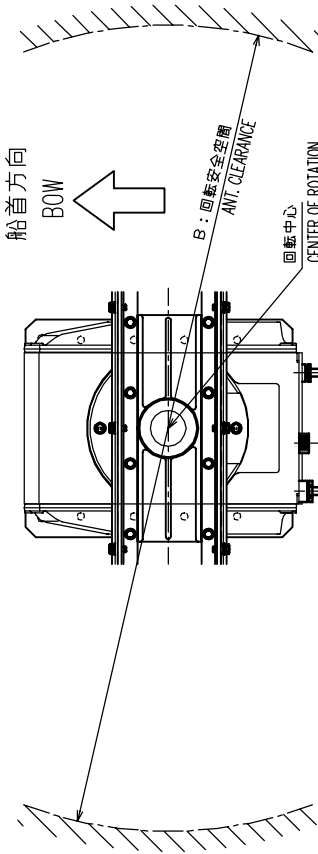
DATE	Mar. 7, '06	E. MIYOSHI	FIG. No.	03-170-3000-0
CHECKED	TAKAHASHI, T.		REF. No.	
APPROVED				
SCALE	1/15	IMSS SEE TABLE 2	NAME	ANTENNA UNIT
			FIG. No.	03-170-3000-0
			MODEL	RSB-111/112
			DEPT.	空中線部
			VIEW	外寸図
				OUTLINE DRAWING

表 1 TABLE 1

寸法区分 (mm) DIMENSIONS	公差 (mm) TOLERANCE
$L \leq 50$	± 1.5
$50 < L \leq 100$	± 2.5
$100 < L \leq 500$	± 3

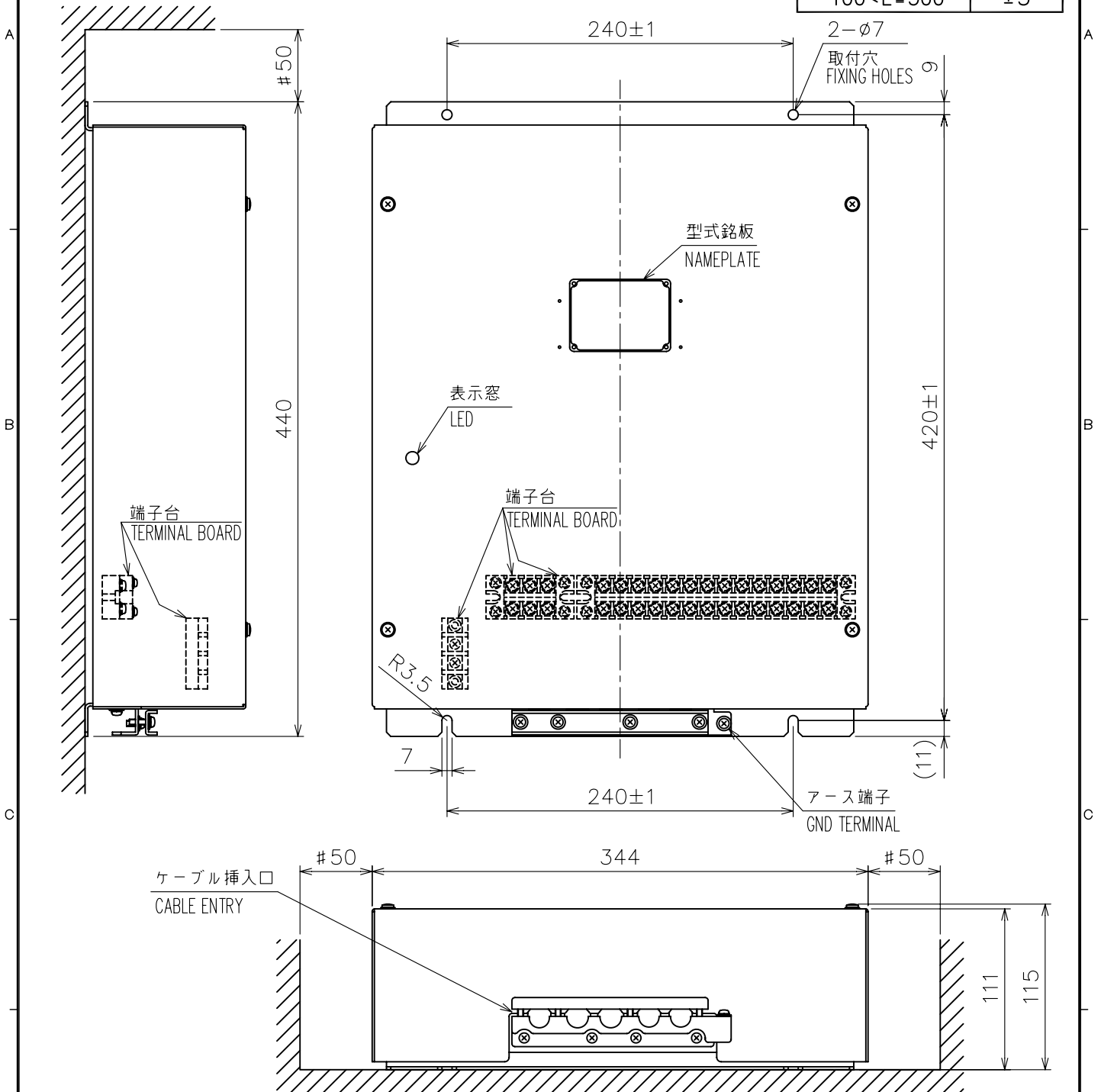

注 記

- #印寸法は最小サービス空間寸法とする。
- 指定外の寸法公差は表 1 による。
- 取付用ネジはトラスタッピンネジ呼び径 6×20 を使用のこと。

NOTE

- #: MINIMUM SERVICE CLEARANCE.
- TABLE 1 INDICATES TOLERANCE OF DIMENSIONS WHICH IS NOT SPECIFIED.
- USE SELF-TAPPING SCREWS 6×20 FOR FIXING THE UNIT.

DRAWN Sep. 19, '06 E. MIYOSHI	TITLE PSU-006
CHECKED TAKAHASHI, T	名称 電源制御部
APPROVED Y. Hatai	FAR-2157/2167DS 外寸図
SCALE 1/4	MASS $5.2 \pm 10\%$ kg
DWG.No. C3523-G01-A	REF.No. 03-171-900G-2
NAME POWER UNIT OUTLINE DRAWING	

表 1 TABLE 1

寸法区分 (mm) DIMENSIONS	公差 (mm) TOLERANCE
$L \leq 50$	± 1.5
$50 < L \leq 100$	± 2.5
$100 < L \leq 500$	± 3

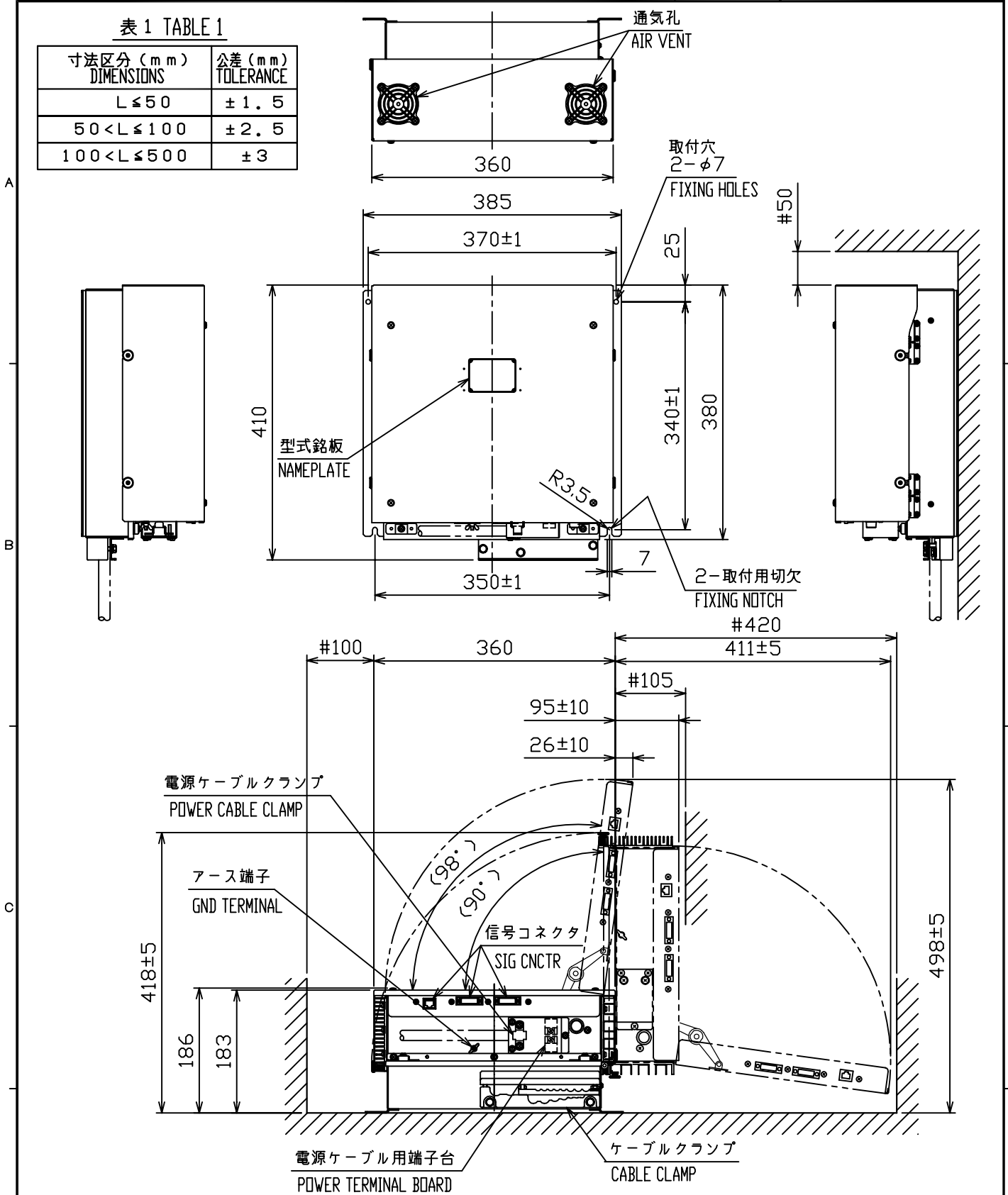

注 記 1) #印寸法は最小サービス空間寸法とする。
 2) 指定外の寸法公差は表 1 による。
 3) 取付けは M6 ボルト、または コーチボルト 呼び径 6 を使用のこと。

NOTE 1. #: MINIMUM SERVICE CLEARANCE.
 2. TABLE 1 INDICATES TOLERANCE OF DIMENSIONS WHICH IS NOT SPECIFIED.
 3. USE M6 BOLTS OR COACH SCREWS φ6 FOR FIXING THE UNIT.

DRAWN Nov 17 '03 E. MIYOSHI	TITLE RPU-013
CHECKED Takahashi T.	名称 制御部
APPROVED Y. Hatai	FAR-2117/2817 SER. 外寸図
SCALE 1/8 MASS 10 ±10% kg	NAME PROCESSOR UNIT
DWG.No. C3519-G03-C	03-163-800G-2 OUTLINE DRAWING

表 1 TABLE 1

寸法区分 (mm) DIMENSIONS	公差 (mm) TOLERANCE
L ≤ 50	± 1.5
50 < L ≤ 100	± 2.5
100 < L ≤ 500	± 3
500 < L ≤ 1000	± 4

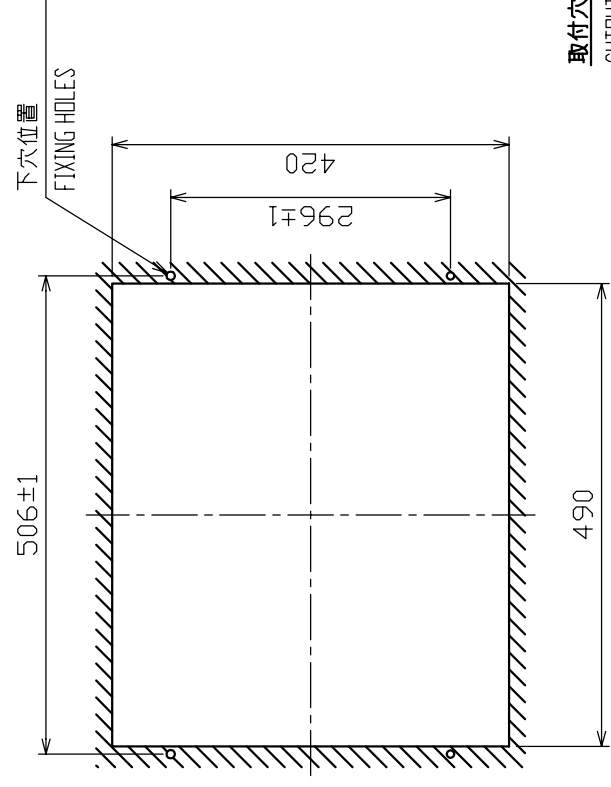
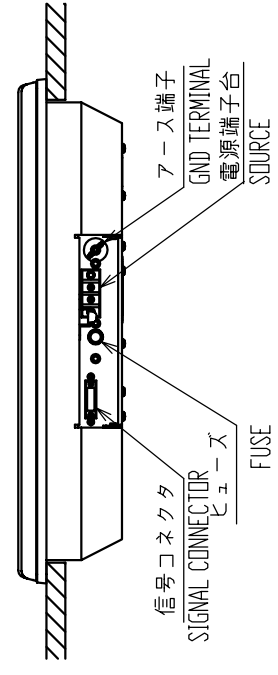
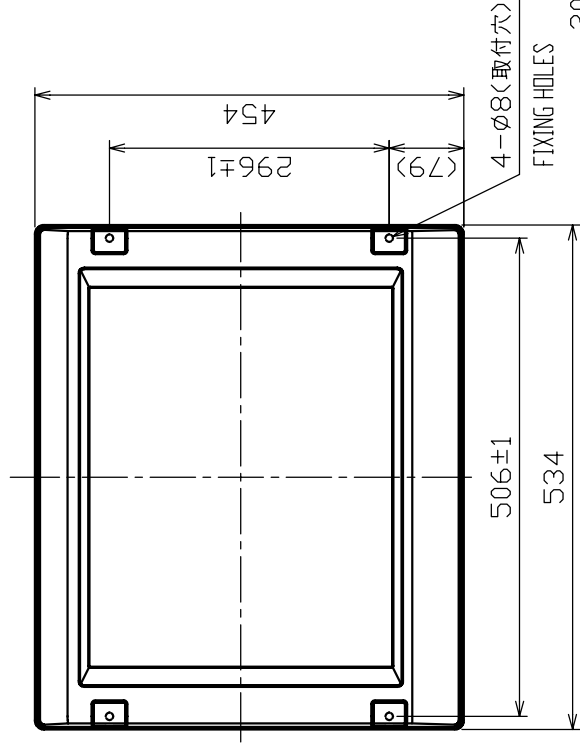
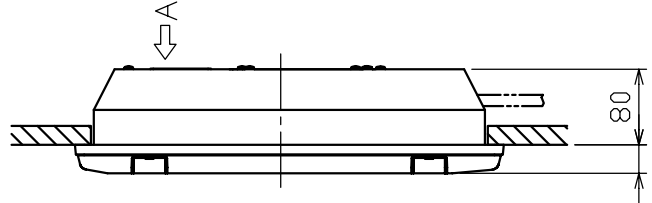
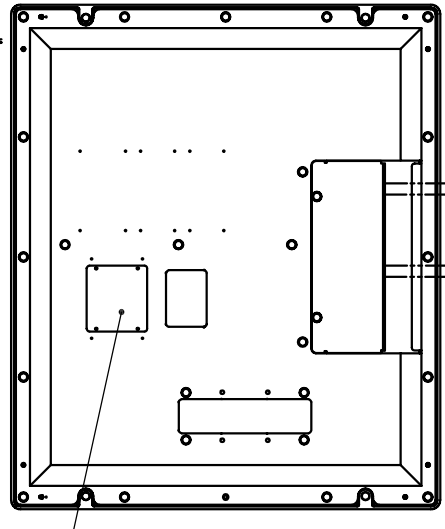

取付穴寸法図
CUTOUT DIMENSIONS

- 注 記 1) 指定外の寸法公差は表 1 による。
 2) 取付には + トラスタップピンネジ 6×30 を使用のこと。
- NOTE 1. TABLE 1 INDICATES TOLERANCE OF DIMENSIONS WHICH IS NOT SPECIFIED.
 2. USE TAPPING SCREWS 6x30 FOR FIXING THE UNIT.

DRAWN Nov. 25 '03 E. MIYOSHI	TITLE MU-20ICR
CHECKED T. akahashi T.	名称 表示部 (埋込装備)
APPROVED Y. Hatai	外寸図
SCALE 1/8	FIG. NO. FAR-2117 SER.
DATE 11.0	NAME MONITOR UNIT (FLUSH MOUNT)
DWG. No. C3519-G05-B	03-163-110G-2
OUTLINE DRAWING	

表 1 TABLE 1

寸法区分 (mm) DIMENSIONS	公差 (mm) TOLERANCE
L ≤ 50	± 1.5
50 < L ≤ 100	± 2.5
100 < L ≤ 500	± 3
500 < L ≤ 1000	± 4

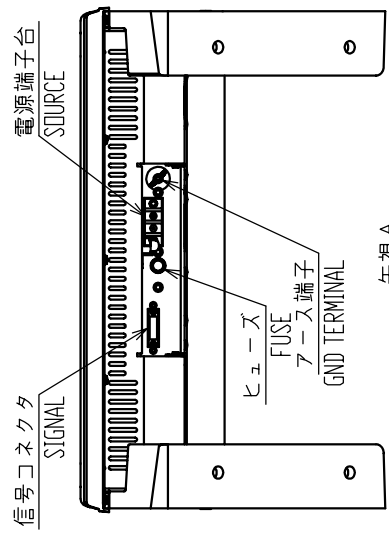

矢視 A
VIEW A

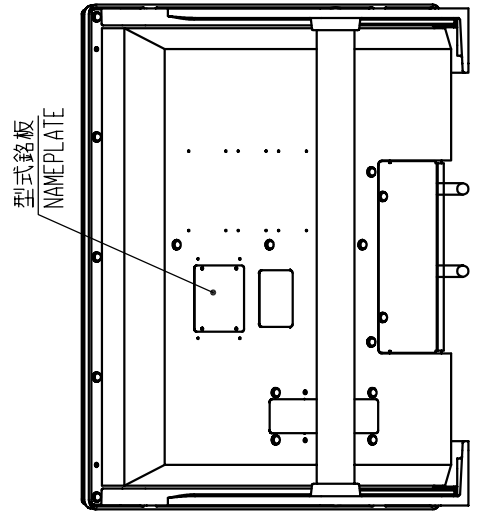
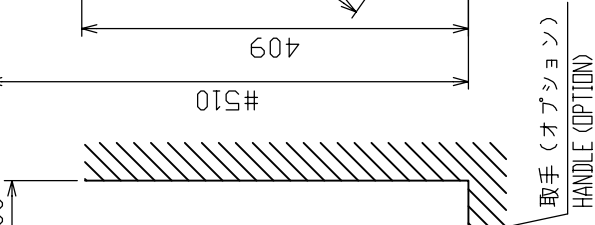
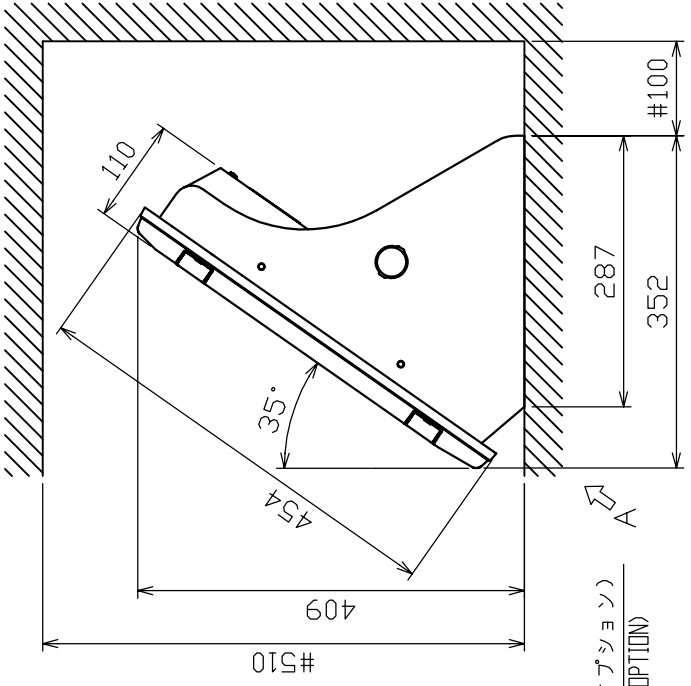

注 記

- 1) #印寸法は最小サービス空間寸法とする。
- 2) 指定外の寸法公差は表1による。
- 3) 取付にはM10ボルトまたはコーチボルト呼び径9を使用のこと。

NOTE

1. # MINIMUM SERVICE CLEARANCE.
2. TABLE 1 INDICATES TOLERANCE OF DIMENSIONS WHICH IS NOT SPECIFIED.
3. USE M10 BOLTS OR COACH SCREWS φ9 FOR FIXING THE UNIT.

DRAWN	Jan. 7 '04	E. MIYOSHI	TITLE	MU-200CR
CHECKED		T. akahashi T.	名称	表示部 (卓上装備)
APPROVED		Y. Hatai	外寸図	
SCALE	1/8	1/8 MASS 17.0 kg	NAME	MONITOR UNIT (DESKTOP MOUNT)
DWG. No.	C3519-G04-B	03-163-100G-2		OUTLINE DRAWING

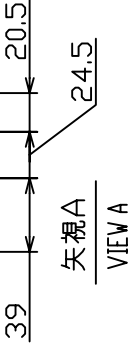
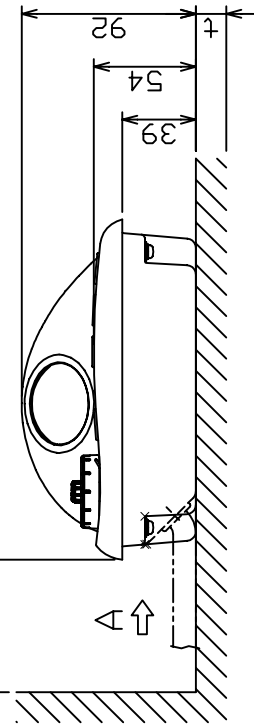
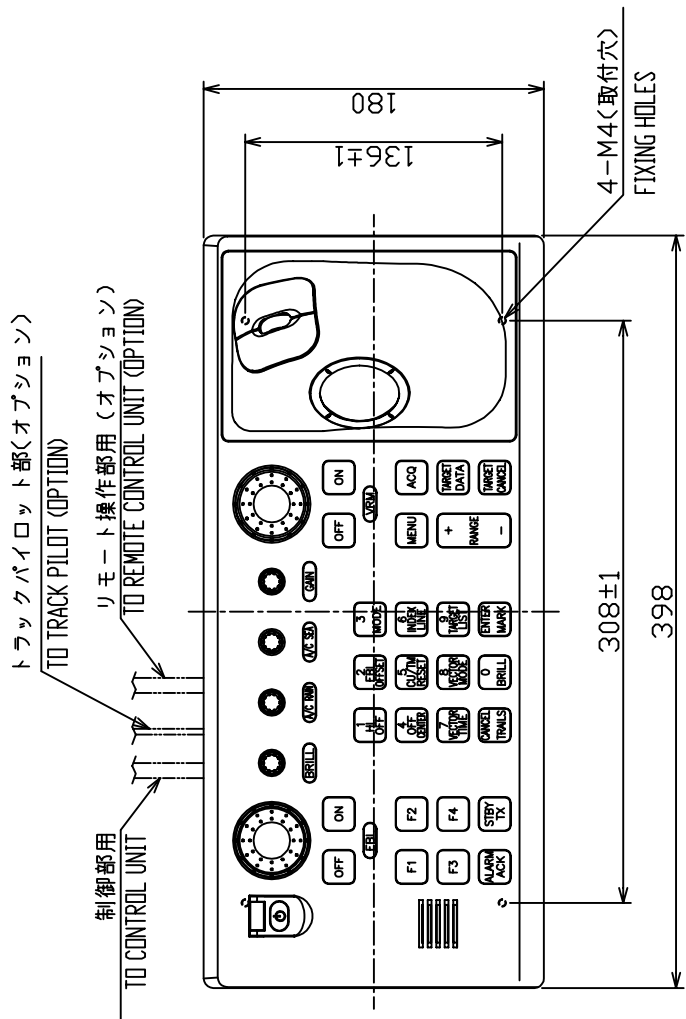

- 注記 1) #印寸法は最小サービス空間寸法とする。
 2) 指定外の寸法公差は表1による。
 3) 取付用ネジはセムスB (M4X (t+4)) を使用のこと。
 4) 質量はケーブル (10m) を含む

- NOTE 1. # MINIMUM SERVICE CLEARANCE.
 2. TABLE 1 INDICATES TOLERANCE OF DIMENSIONS WHICH IS NOT SPECIFIED.
 3. USE SEMS SCREWS M4X(t+4) FOR FIXING THE UNIT.
 4. MASS INCLUDES CABLE (10M).

表 1 TABLE 1

寸法区分 (mm) DIMENSIONS	公差 (mm) TOLERANCE
L ≤ 50	± 1.5
50 < L ≤ 100	± 2.5
100 < L ≤ 500	± 3

DRAWN	Jun. 26 '03 E. MIYOSHI	TITLE	RCU-014
CHECKED	Takahashi T.	名称	操作部
APPROVED	Y. Hatai	外寸図	
SCALE	1/4 MASS 3.7 kg	NAME	CONTROL UNIT
DMG No.	C3519-006-C	OUTLINE DRAWING	
		FAR-2117/2817 SER.	
		03-163-7506-3	

表 1 TABLE 1

寸法区分 (mm) DIMENSIONS	公差 (mm) TOLERANCE
L ≤ 50	± 1.5
50 < L ≤ 100	± 2.5
100 < L ≤ 500	± 3

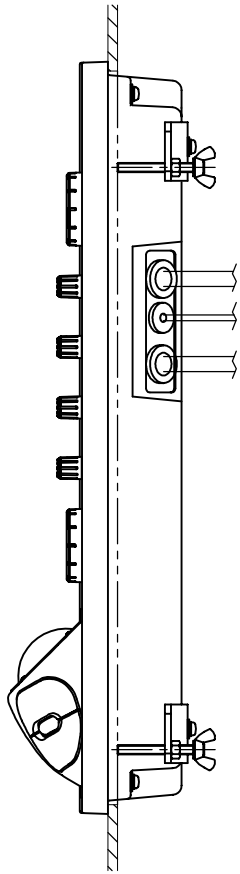

矢視 A
VIEW A

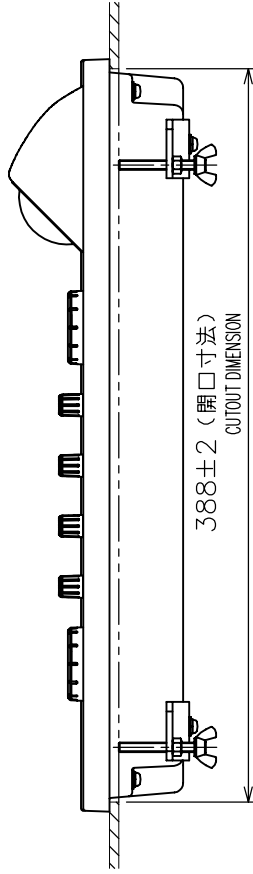
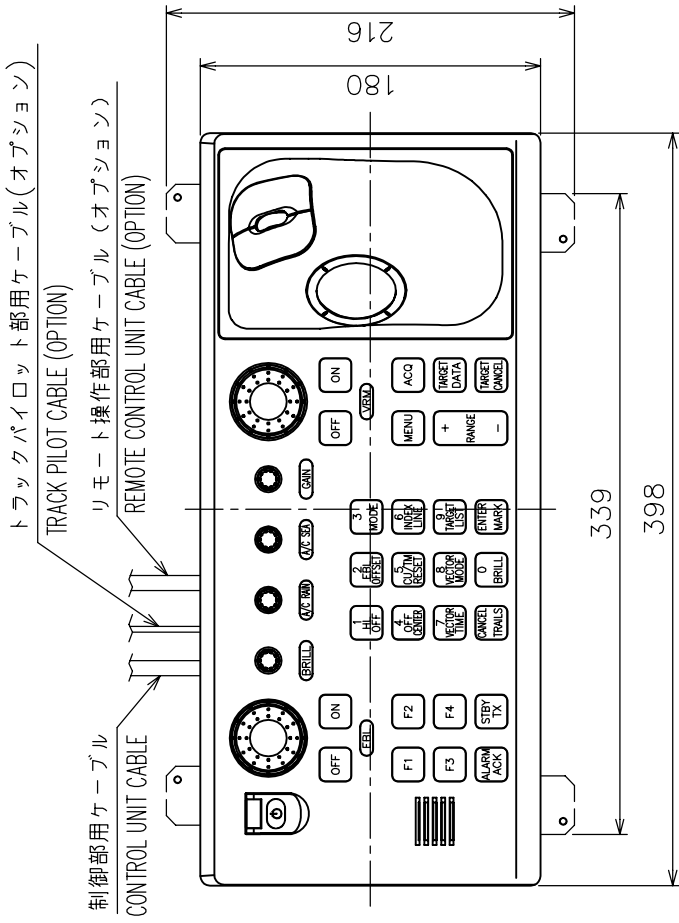
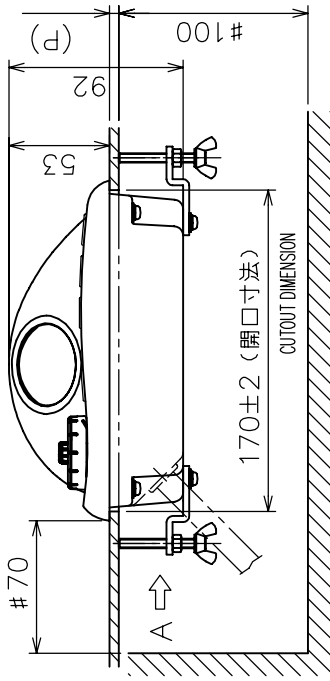

- NOTE
1. # MINIMUM SERVICE CLEARANCE.
 2. TABLE 1 INDICATES TOLERANCE OF DIMENSIONS WHICH IS NOT SPECIFIED.
 3. MASS INCLUDES CABLE (10M).
 4. THICKNESS (P) 20 MM MAX.

- 注 記
- 1) #印寸法は最小サービス空間寸法とする。
 - 2) 指定外の寸法公差は表1による。
 - 3) 質量はケーブル(10m)を含む
 - 4) 壁の厚さ(P)は最大20とする

DRAWN	Mr. 17.04 E. MIYOSHI	TITLE	RCU-014
CHECKED	TAKAHASHI, T	名 称	操作部 (埋込装備)
APPROVED	Y. Hatai	外寸図	
SCALE	1/4 MASS 3.8 ±10% kg	NAME	CONTROL UNIT (FLUSH MOUNT)
DWG.No.	C3524-G04-C		OUTLINE DRAWING
	FAR-2817 SER.		
	03-163-751G-2		

表 1 TABLE 1

寸法区分 (mm) DIMENSIONS	公差 (mm) TOLERANCE
L ≤ 50	± 1.5
50 < L ≤ 100	± 2.5
100 < L ≤ 500	± 3

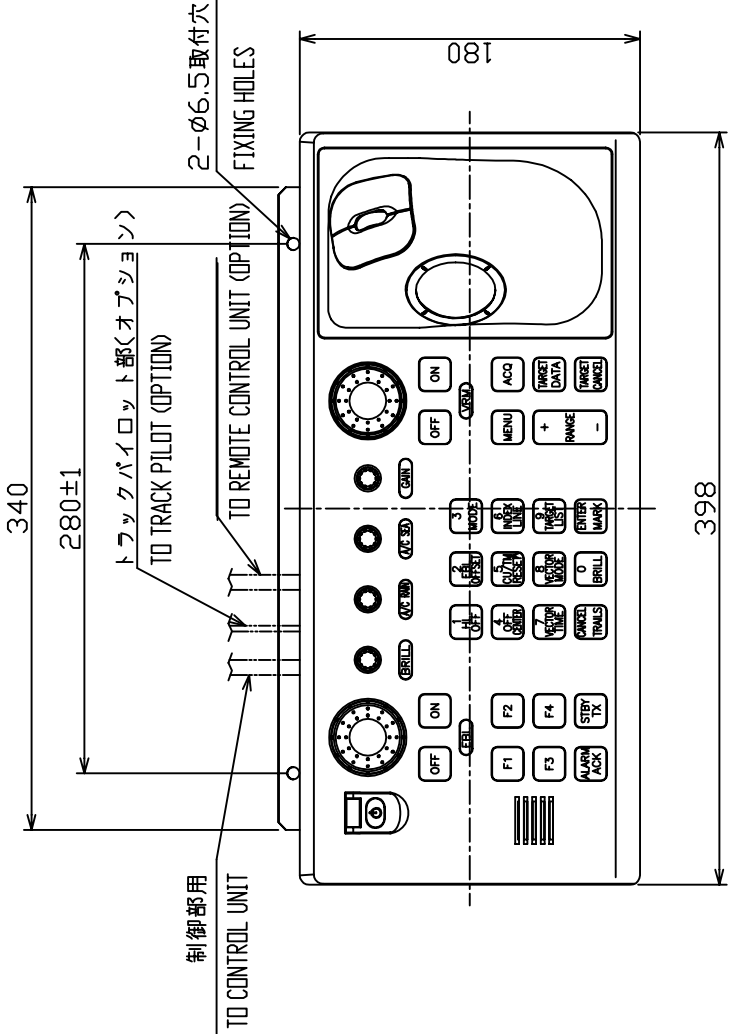
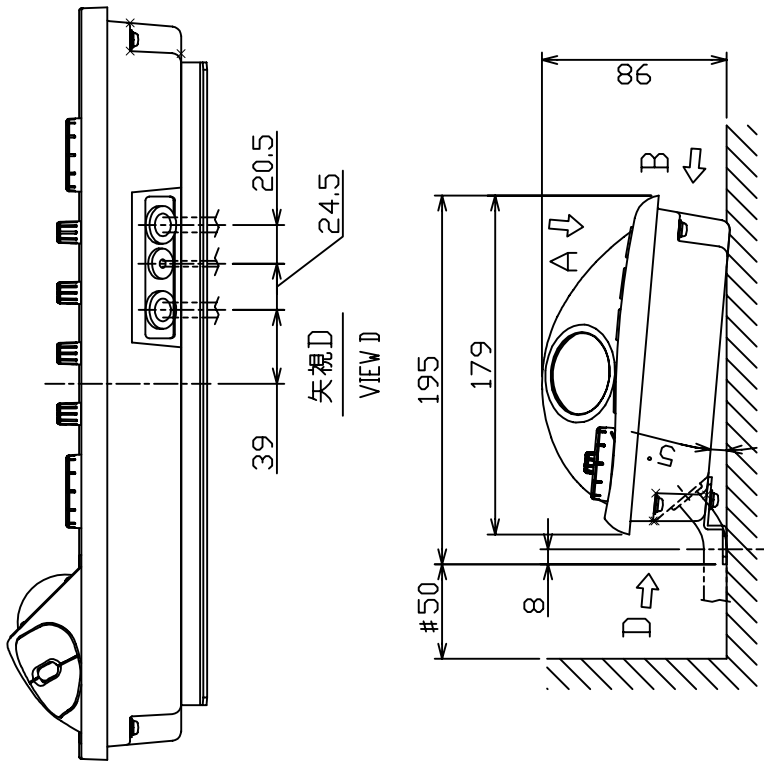

矢視A VIEW A

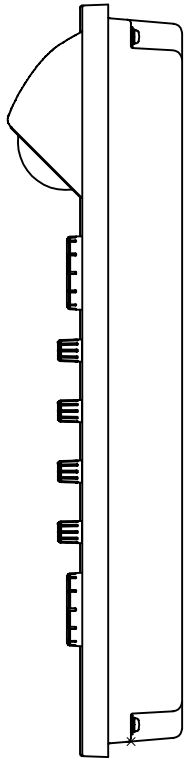

矢視B VIEW B

- NOTE 1. # MINIMUM SERVICE CLEARANCE.
 2. TABLE 1 INDICATES TOLERANCE OF DIMENSIONS WHICH IS NOT SPECIFIED.
 3. USE TAPPING SCREWS (φ6) OR M6 BOLTS FOR FIXING.
 4. MASS INCLUDES CABLE (10M).

- 注記 1) #印寸法は最小サービス空間寸法とする。
 2) 指定外の寸法公差は表1による。
 3) 取付用ネジはトラスタックピソネジ呼び径6、またはM6ボルトを使用のこと
 4) 質量はケーブル(10m)を含む

DRAWN	Jan. 7 '04	E. MIYOSHI	TITLE	RCU-014
CHECKED		Takahashi T.	名称	操作部 (直付金具装備)
APPROVED		Y. Hatai	外寸図	
SCALE	1/4	MASS 4.0 kg	NAME	CONTROL UNIT (DESKTOP W/KB PLATE)
DWG No.	C3524-005-B	03-163-752G-1		OUTLINE DRAWING

表 1 TABLE 1

寸法区分 (mm) DIMENSIONS	公差 (mm) TOLERANCE
L ≤ 50	± 1.5
50 < L ≤ 100	± 2.5
100 < L ≤ 500	± 3

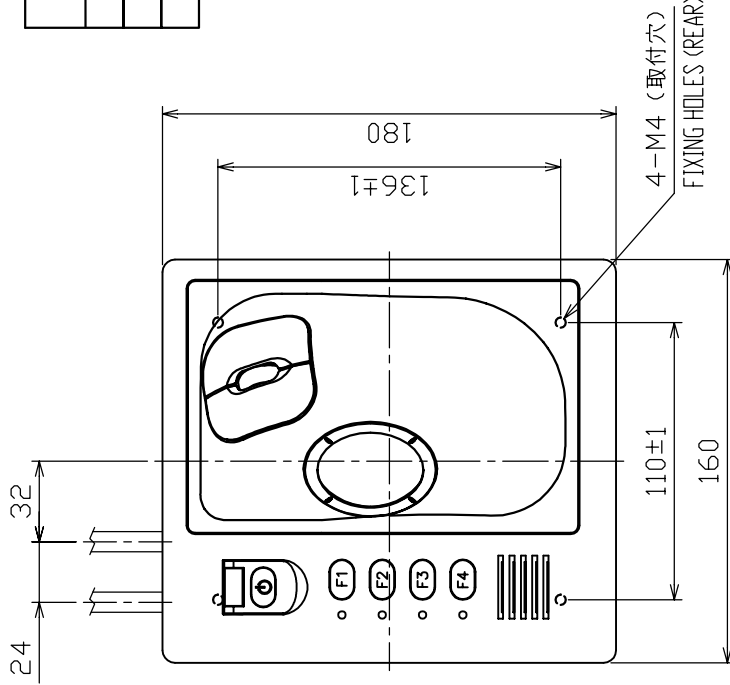

NOTE

- # MINIMUM SERVICE CLEARANCE.
- TABLE 1 INDICATES TOLERANCE OF DIMENSIONS WHICH IS NOT SPECIFIED.
- USE M4X12 SCREWS FOR FIXING. THICKNESS OF MOUNTING SURFACE SHOULD BE 2.5 CM. FOR GREATER THICKNESS USE SCREW WHOSE LENGTH IS (M4X(t+7.8)) ±2.
- MASS INCLUDES CABLE (10).

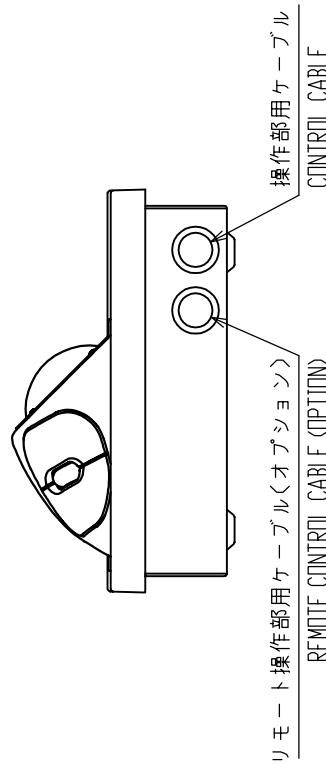
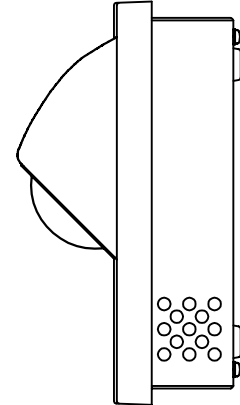

矢視A
VIEW A

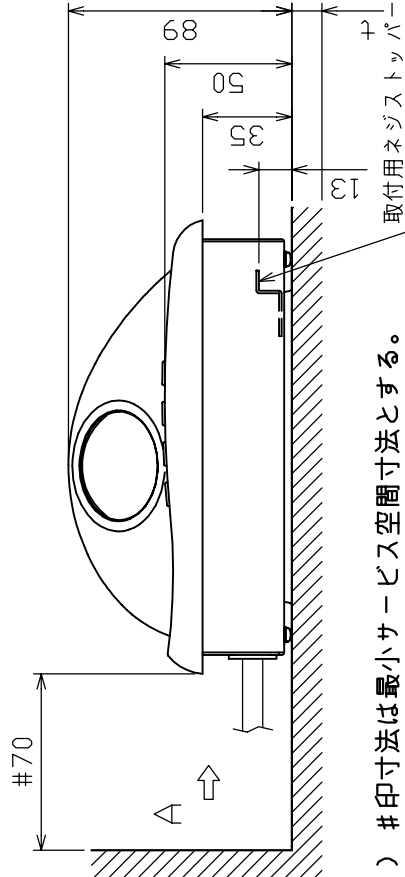

- 注 記
- # 印寸法は最小サービス空間寸法とする。
 - 指定外の寸法公差は表 1 による。
 - 取付用ネジはセムスB (M4X12) を使用のこと。
取付面板厚は最小2最大5とする。
それ以外はネジ長さ (M4X (t + 7.8)) ± 2 のセムスBを使用のこと。
質量はケーブル (10m) を含む。
 - 4) 質量はケーブル (10m) を含む。

DRAWN	Jun. 7/04	E. MIYOSHI	TITLE	RCU-015
CHECKED		Takahashi T.	名称	操作部 (卓上装備)
APPROVED		Y. Hatai	外寸図	
SCALE	1/3	MASS 2.4 kg	NAME	CONTROL UNIT (DESKTOP MOUNT)
JUNING	C3519-G13-B	03-163-785G-2		OUTLINE DRAWING

表 1 TABLE 1

寸法区分 (mm) DIMENSIONS	公差 (mm) TOLERANCE
$L \leq 50$	± 1.5
$50 < L \leq 100$	± 2.5
$100 < L \leq 500$	± 3

操作部用ケーブル
CONTROL UNIT CABLE

リモート操作部用ケーブル (オプション)
REMOTE CONTROL UNIT CABLE (OPTION)

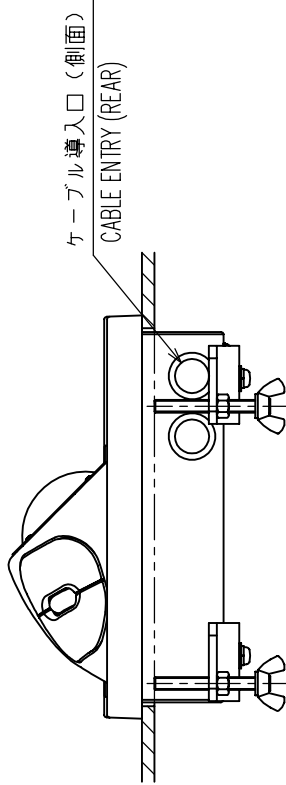

矢視 A
VIEW A

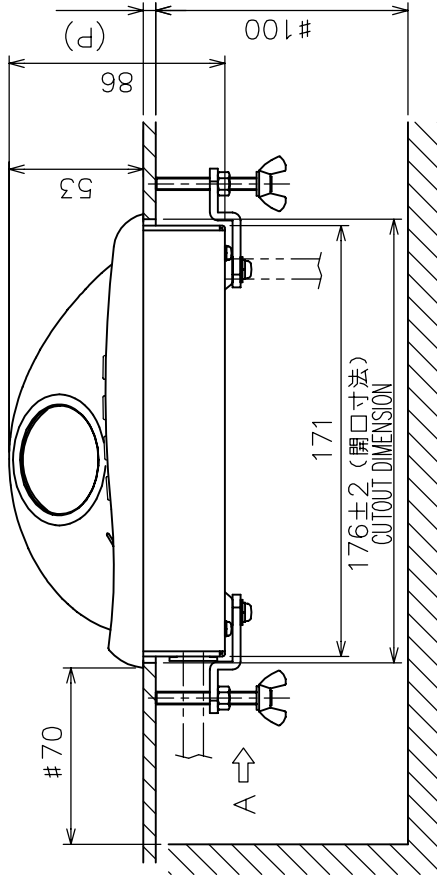
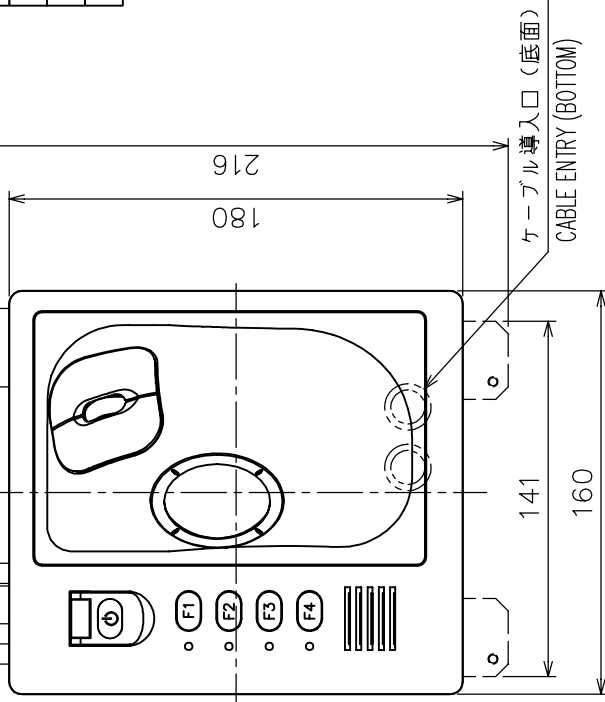

注 記

- 1) #印寸法は最小サービス空間寸法とする。
- 2) 指定外の寸法公差は表 1 による。
- 3) ケーブル導入口は側面・底面から選択のこと。
- 4) 壁の厚さ (P) は最大 10 とする
- 5) 質量はケーブル (10m) を含む

NOTE

1. # MINIMUM SERVICE CLEARANCE.
2. TABLE 1 INDICATES TOLERANCE OF DIMENSIONS WHICH IS NOT SPECIFIED.
3. SELECT CABLE ENTRY FROM REAR OR SIDE.
4. THICKNESS (P) 10 MM MAX.
5. MASS INCLUDES CABLE (10M).

DRAWN	Mar. 17 '04	E. MIYOSHI	TITLE	RCU-015
CHECKED		TAKAHASHI, T	名称	トラックボール操作部 (埋込装備)
APPROVED		Y. Hatai	外寸図	
SCALE	1/3	質量は 10m ケーブルを含む #104 MASS 2.5 kg	NAME	TRACKBALL CONTROL UNIT (FLUSH MOUNT)
DWG.No.	C3519-G14-C	03-163-786G-2	OUTLINE DRAWING	

表 1 TABLE 1

寸法区分 (mm) DIMENSIONS	公差 (mm) TOLERANCE
L ≤ 50	± 1.5
50 < L ≤ 100	± 2.5
100 < L ≤ 500	± 3

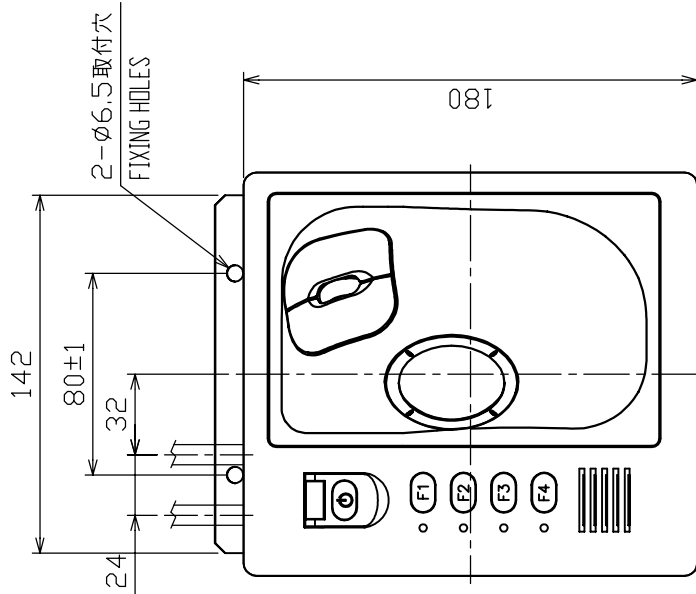

矢視 A
VIEW A

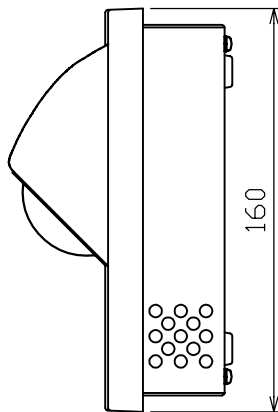

矢視 B
VIEW B

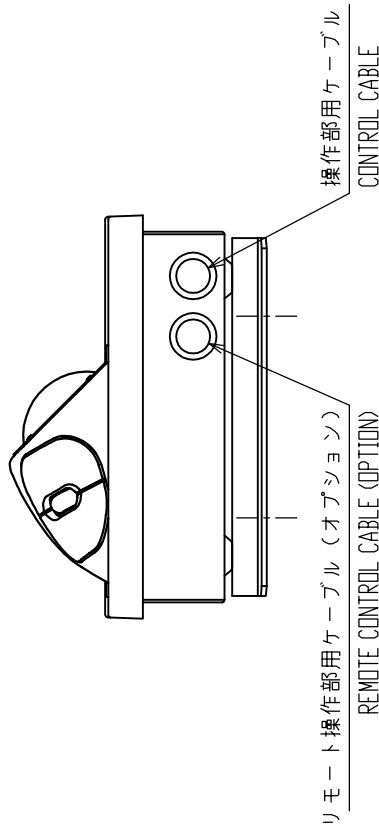

矢視 D
VIEW D

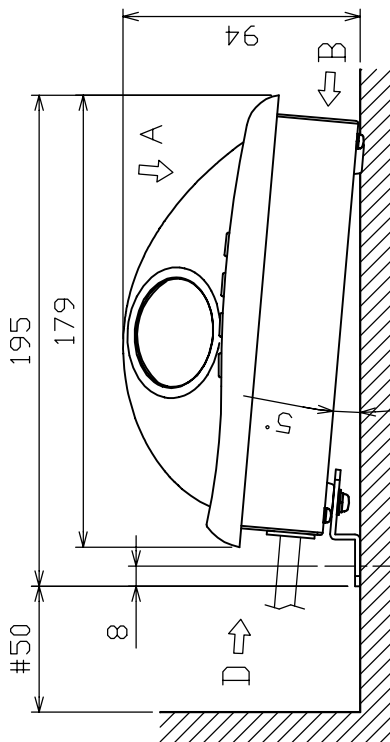

注 記

- 1) #印寸法は最小サービス空間寸法とする。
- 2) 指定外の寸法公差は表 1 による。
- 3) 取付にはトラスタップピンネジ呼び径6またはM6ボルトを使用のこと。
- 4) 質量はケーブル(10m)を含む

NOTE

1. #: MINIMUM SERVICE CLEARANCE.
2. TABLE 1 INDICATES TOLERANCE OF DIMENSIONS WHICH IS NOT SPECIFIED.
3. USE TAPPING SCREWS #6 OR M6 BOLTS FOR FIXING THE UNIT.
4. MASS INCLUDES CABLE (10M).

DRAWN	Jan. 7 '04	E. MIYOSHI	TITLE	RCU-015
CHECKED		Takahashi T.	名称	操作部 (取付金具装備)
APPROVED		Y. Hatai	外寸図	
SCALE	1/3	質量は10mケーブル質量を含む。 MASS W/ 10m CABLE	NAME	CONTROL UNIT (TABLETOP MOUNT W/ FIXTURE)
DMGNo.	C3519-G15-B	03-163-787G-1		OUTLINE DRAWING

表 1 TABLE 1

寸法区分 (mm) DIMENSIONS	公差 (mm) TOLERANCE
L ≤ 50	± 1.5
50 < L ≤ 100	± 2.5
100 < L ≤ 500	± 3

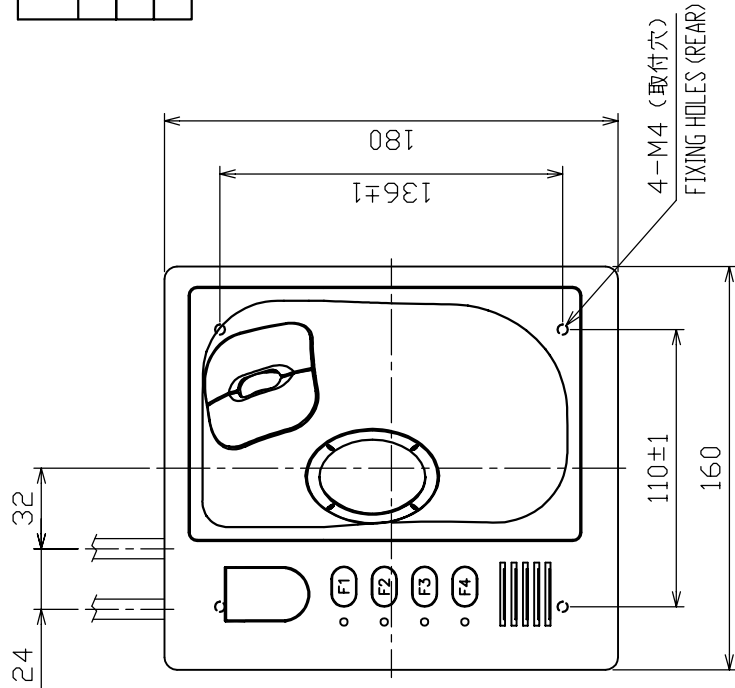

NOTE

1. # MINIMUM SERVICE CLEARANCE.
2. TABLE 1 INDICATES TOLERANCE OF DIMENSIONS WHICH IS NOT SPECIFIED.
3. USE M4x12 SCREWS FOR FIXING. THICKNESS OF MOUNTING SURFACE SHOULD BE 2.5 CM. FOR GREATER THICKNESS USE SCREW WHOSE LENGTH IS (M4X(+7.8)) ± 2.
4. MASS INCLUDES CABLE (10).

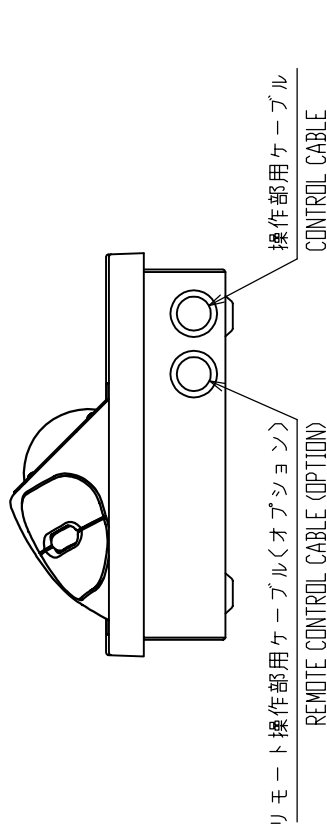
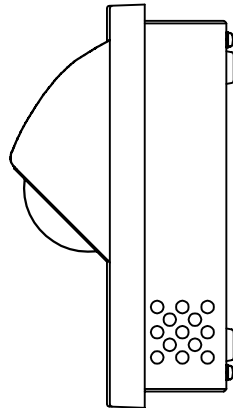

矢視A
VIEW A

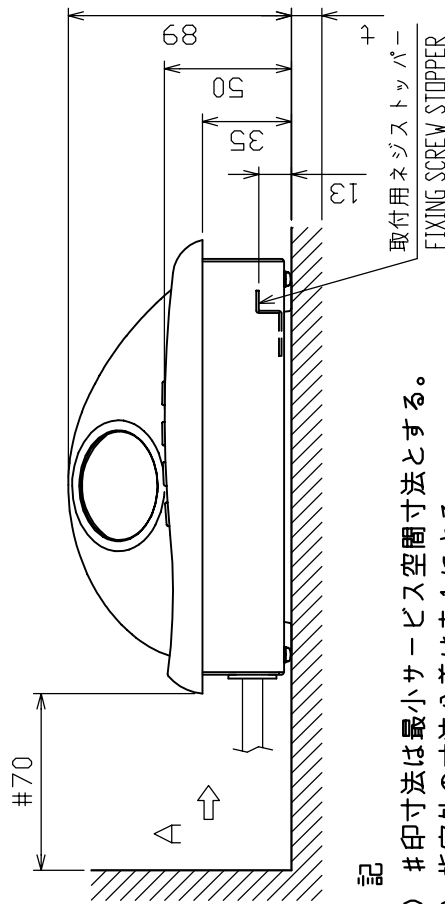

注 記

- 1) # 印寸法は最小サービス空間寸法とする。
- 2) 指定外の寸法公差は表 1 による。
- 3) 取付用ネジはセムスB (M4X12) を使用のこと。
取付面板厚は最小 2 最大 5 とする。
それ以外はネジ長さ (M4X (+7.8)) ± 2 のセムスB を使用のこと。
4) 質量はケーブル (10m) を含む

DRAWN	June. 19 03. E. MIYUSHI	TITLE	RCU-016
CHECKED	Takahashi T.	名称	操作部 (卓上装備)
APPROVED	Y. Hatai	外寸図	
SCALE	1/3 MASS 2.4 kg	FAR-2117 SER	CONTROL UNIT (DESKTOP MOUNT)
DWG No.	C3519-G16-B	質量はケーブルを含む。	OUTLINE DRAWING
		03-163-780G-3	

表 1 TABLE 1

寸法区分 (mm) DIMENSIONS	公差 (mm) TOLERANCE
L ≤ 50	± 1.5
50 < L ≤ 100	± 2.5
100 < L ≤ 500	± 3

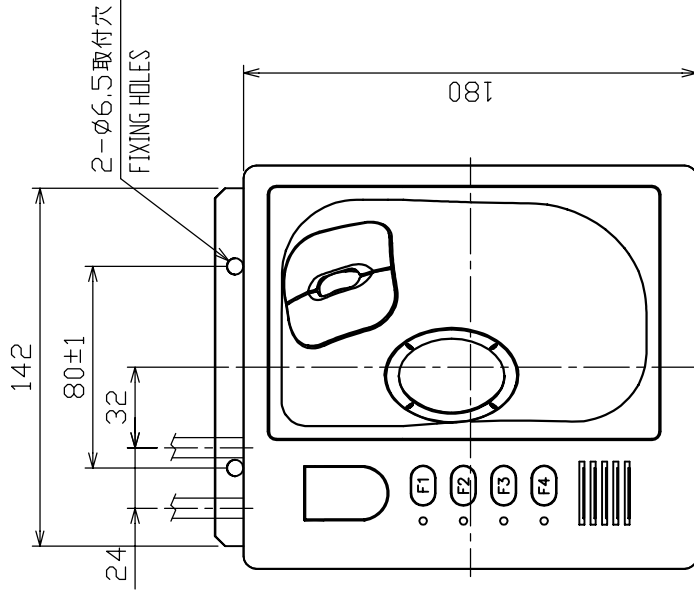

矢視 A
VIEW A

矢視 B
VIEW B

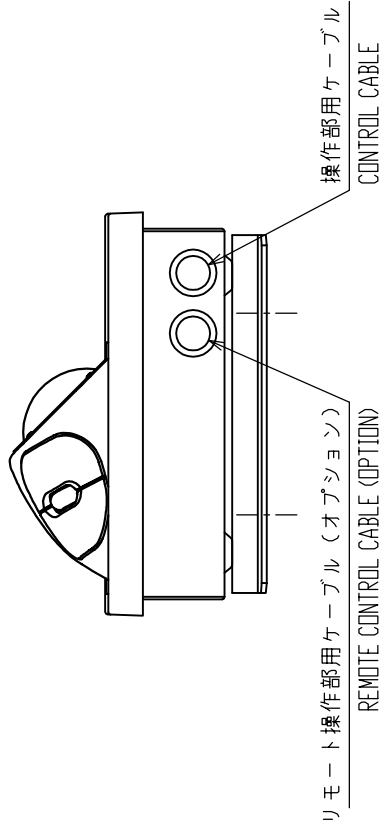
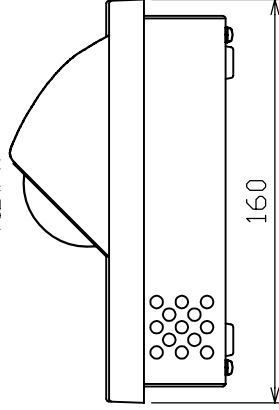

矢視 D
VIEW D

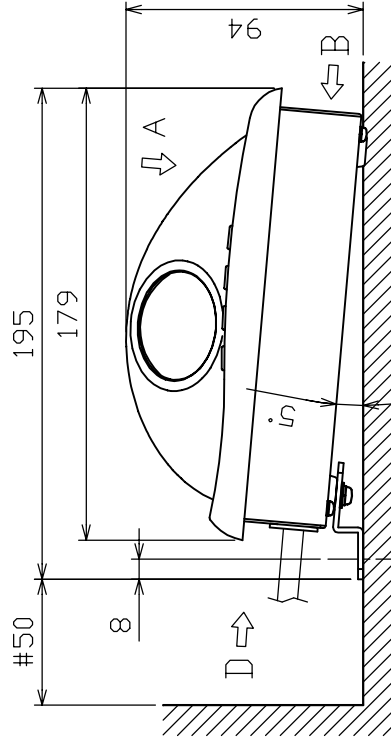

注 記

- 1) #印寸法は最小サービスクリアランスとする。
- 2) 指定外の寸法公差は表 1 による。
- 3) 取付用ネジはトラスクピネジ呼び径6、またはM6ボルトを使用のこと。
- 4) 質量はケーブル (10m) を含む

NOTE

1. # MINIMUM SERVICE CLEARANCE.
2. TABLE 1 INDICATES TOLERANCE OF DIMENSIONS, WHICH IS NOT SPECIFIED.
3. USE TAPPING SCREWS φ6 OR M6 BOLTS FOR FIXING THE UNIT.
4. MASS INCLUDES CABLE (10M).

DRAWN	Y. HATAI	TITLE	RCU-016
CHECKED	E. MIYOSHI Takahashi T.	名称	操作部 (取付金具装備)
APPROVED	Y. Hatai	外寸図	
SCALE	1/3	NAME	CONTROL UNIT (TABLETOP MOUNT W/ FIXTURE)
DWG No.	C3519-G12-B		OUTLINE DRAWING

表 1 TABLE 1

寸法区分 (mm) DIMENSIONS	公差 (mm) TOLERANCE
$L \leq 50$	± 1.5
$50 < L \leq 100$	± 2.5
$100 < L \leq 500$	± 3

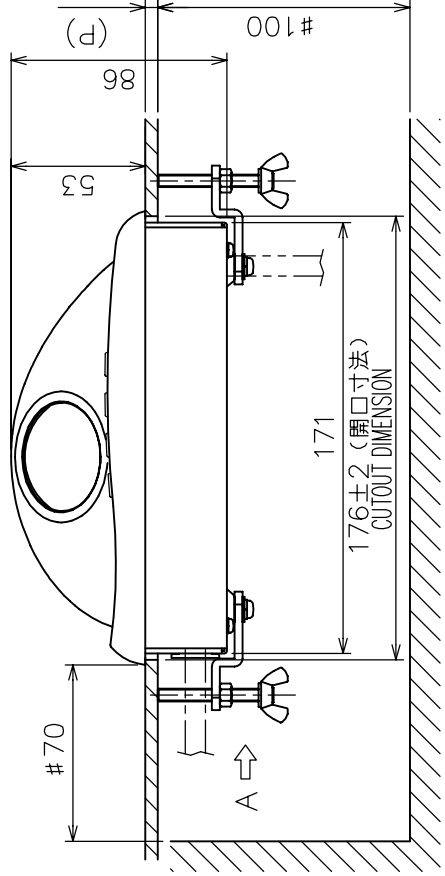
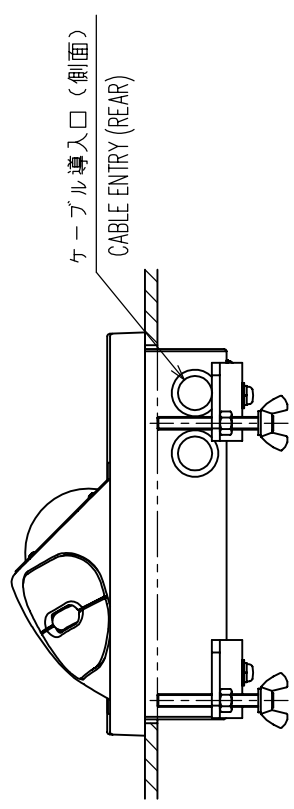
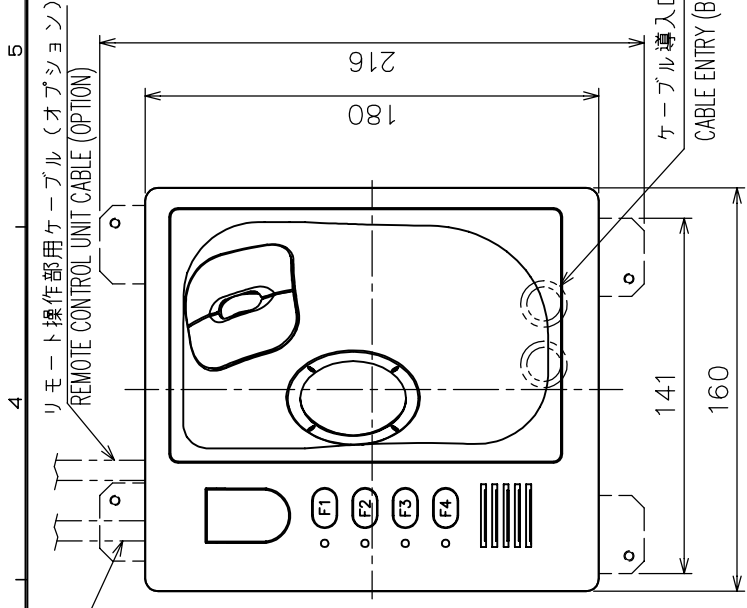

注 記

- 1) #印寸法は最小サージス空間寸法とする。
- 2) 指定外の寸法公差は表 1 による。
- 3) ケーブル導入口は側面・底面から選択のこと。
- 4) 壁の厚さ (P) は最大 10 とする
- 5) 質量はケーブル (10m) を含む

NOTE

1. # MINIMUM SERVICE CLEARANCE.
2. TABLE 1 INDICATES TOLERANCE OF DIMENSIONS. WHICH IS NOT SPECIFIED.
3. SELECT CABLE ENTRY FROM REAR OR SIDE.
4. THICKNESS (P) 10 MM MAX.
5. MASS INCLUDES CABLE (10M).

DRAWN	Apr. 17 '04	E. MIYOSHI	TITLE	RCU-016
CHECKED		TAKAHASHI, T	名称	リモート操作部 (埋込装備)
APPROVED		Y. Hatai	外寸図	
SCALE	1/3	FAR-2117 SER. #10M 質量は10mケーブルを含む。 MASS W/ 10m CABLE	NAME	REMOTE CONTROL UNIT (FLUSH MOUNT)
DWG.No.	C3519-G11-C	03-163-781G-3	OUTLINE DRAWING	

表 1 TABLE 1

寸法区分 (mm) DIMENSIONS	公差 (mm) TOLERANCE
L ≤ 50	±1.5
50 < L ≤ 100	±2.5
100 < L ≤ 500	±3

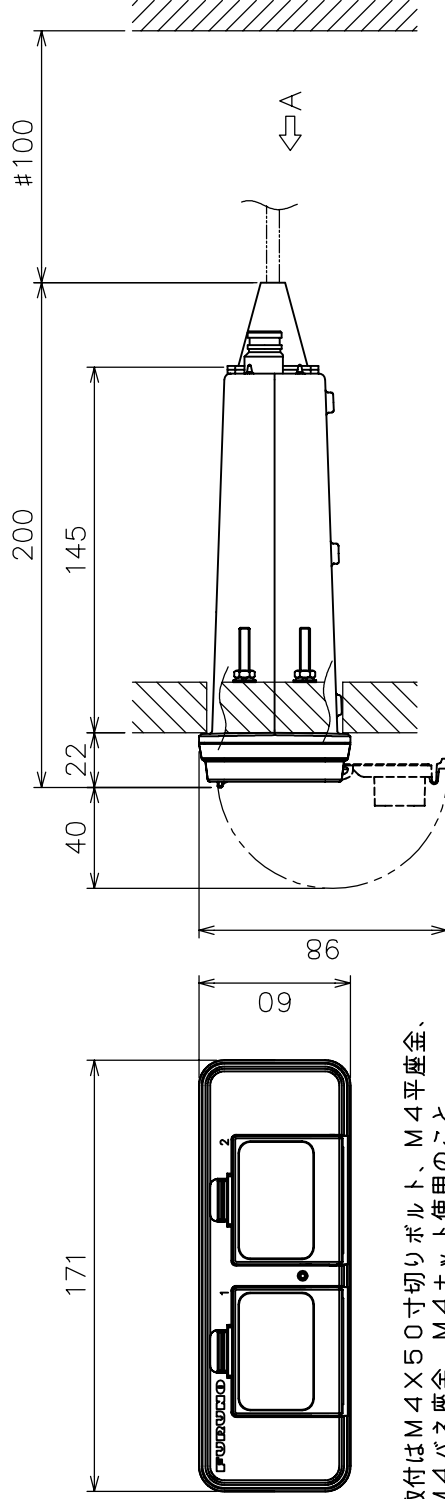
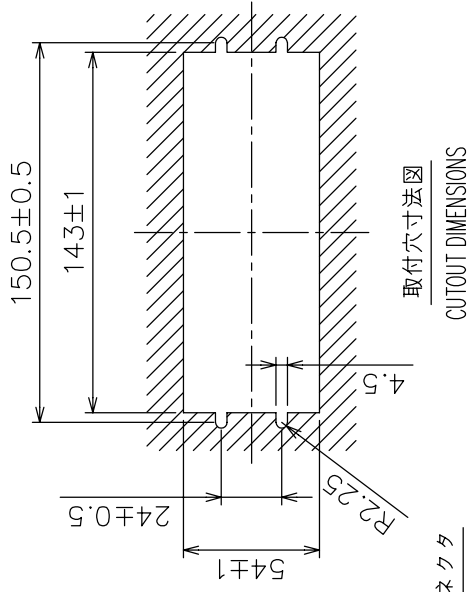
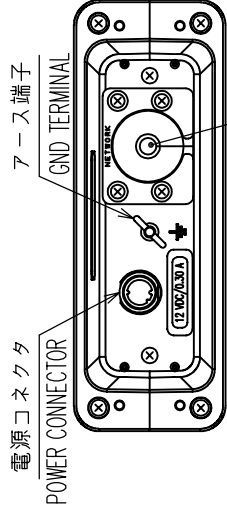
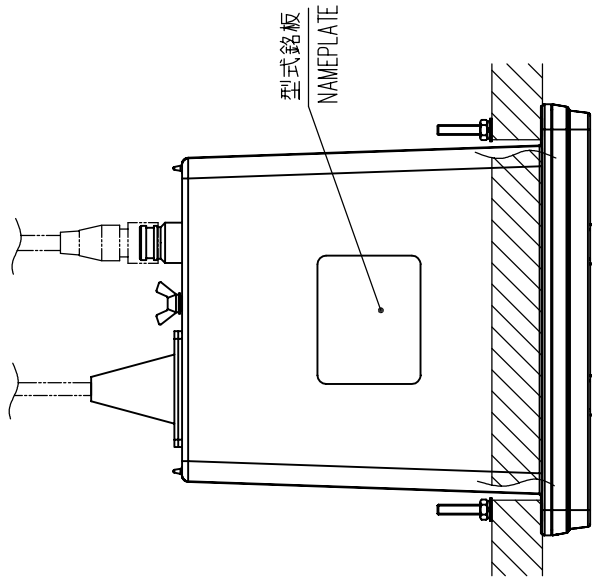

- 注 記
- 1) 取付は M4X50 寸切りボルト、M4 平座金、M4 バネ座金、M4 ナット使用のこと。
 - 2) # 印寸法は最小サービスクリアランスとする。
 - 3) 指定外の寸法公差は表 1 による。

- NOTE
1. USE M4X50 BOLTS, M4 FLAT WASHERS, M4 SPRING WASHERS AND M4 NUTS FOR FIXING.
 2. # MINIMUM SERVICE CLEARANCE.
 3. TABLE 1 INDICATES TOLERANCE OF DIMENSIONS WHICH IS NOT SPECIFIED.

DRAWN	Mar. 29 '04 E. MIYOSHI	FAR-2117 SERIES	TITLE	CU-200
CHECKED	TAKAHASHI, T	MODEL 1833C	名称	防水型カードインターフェース(埋込装備)
APPROVED	Y. Hatai	MODEL 1833C-BB	外寸図	
SCALE	1/3	1/3	NAME	MEMORY CARD INTERFACE UNIT (FLUSH MOUNT)
DWG.No.	C3532-004-B	19-023-300G-1		OUTLINE DRAWING



表 1 TABLE 1

寸法区分 (mm) DIMENSIONS	公差 (mm) TOLERANCE
L ≤ 50	± 1.5
50 < L ≤ 100	± 2.5
100 < L ≤ 500	± 3



矢視 A
VIEW A

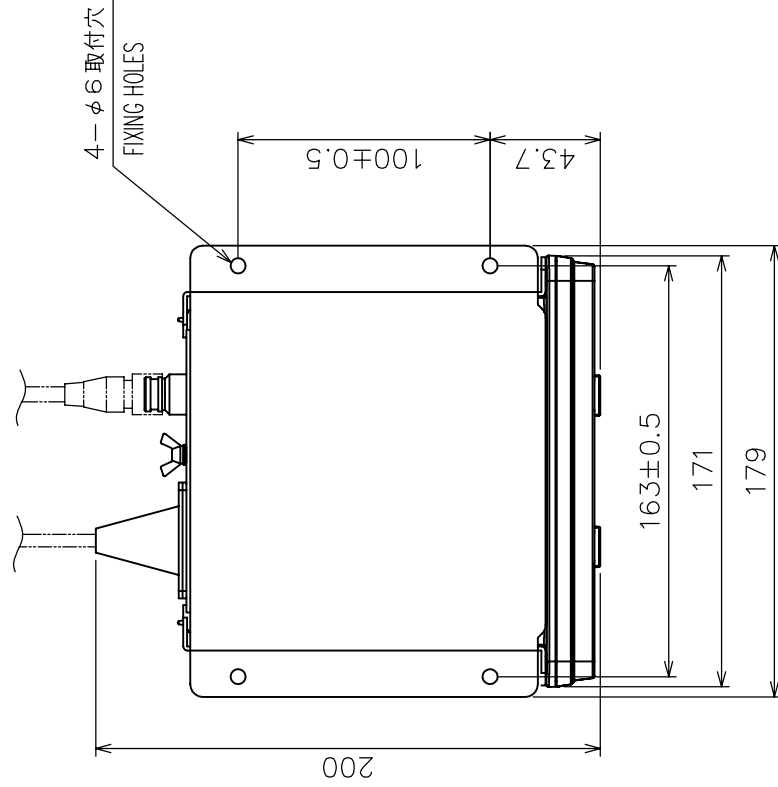
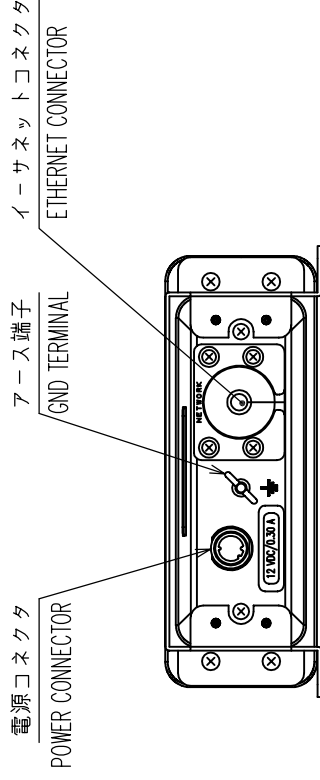
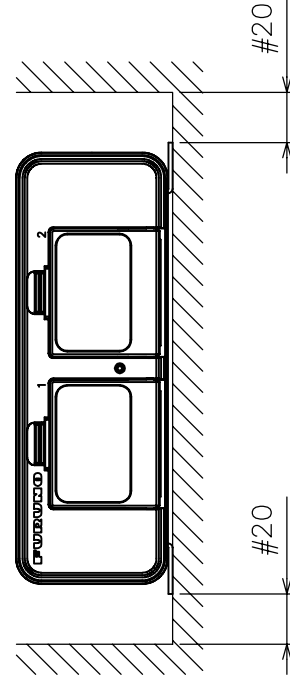
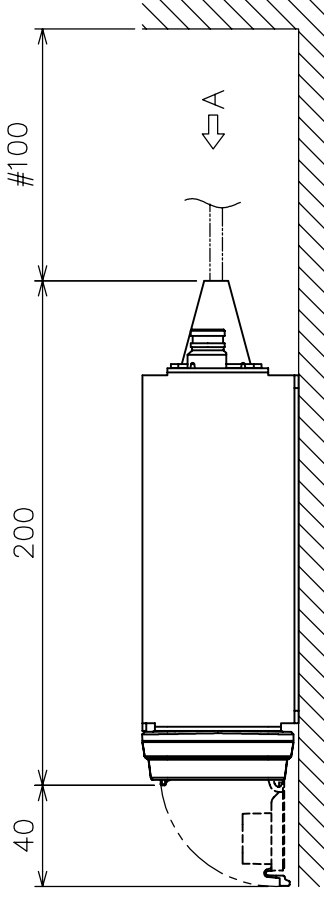

- 注 記
- # 印寸法は最小サービス空間寸法とする。
 - 指定外の寸法公差は表 1 による。
 - 取付用ネジは + トラスタップピンネジ呼び径 5 × 2.0 を使用のこと。
- NOTE
- # MINIMUM SERVICE CLEARANCE.
 - TABLE 1 INDICATES TOLERANCE OF DIMENSIONS WHICH IS NOT SPECIFIED.
 - USE SELF-TAPPING SCREWS 5X2.0 FOR FIXING THE UNIT.

DRAWN	Mar. 29 '04	E. MIYOSHI	FAR-2117 SERIES	TITLE	CU-200
CHECKED		TAKAHASHI, T	MODEL 1833C	名 称	防水型カードインターフェイス(卓上装備)
APPROVED		Y. Hatai	MODEL 1833C-BB		外 寸 図
SCALE	1/3	1/MS	FORM 1.3	NAME	MEMORY CARD INTERFACE UNIT (TABLETOP MOUNT)
DWG. No.	C3532-005-B		19-023-310G-1		OUTLINE DRAWING

注記

- 1) #印寸法は最小サービス空間寸法とする。
- 2) 指定外の寸法公差は表1による。
- 3) 取付用ナットはM4ナットを使用のこと。
- 4) 取付板厚は最大8mmとする。

NOTE

1. # MINIMUM SERVICE CLEARANCE.
2. TABLE 1 INDICATES TOLERANCE OF DIMENSIONS WHICH IS NOT SPECIFIED.
3. USE NUT M4 FOR FIXING THE UNIT.
4. MAX. MOUNTING BASE THICKNESS IS 8 MM.



表 1 TABLE 1

寸法区分 (mm) DIMENSIONS	公差 (mm) TOLERANCE
L ≤ 50	± 1.5
50 < L ≤ 100	± 2.5
100 < L ≤ 500	± 3



DRAWN	Mar. 29, '04 E. MIYOSHI	FAR-2117 SERIES	TITLE	CU-200
CHECKED	TAKAHASHI, T	MODEL 1833C	名 称	防水型カードインターフェイス(天井装備)
APPROVED	Y. Hatai	MODEL 1833C-BB	外寸図	
SCALE	1/3	1/3	NAME	MEMORY CARD INTERFACE UNIT (OVERHEAD MOUNT)
DWG.No.	C3532-006-B	19-023-320G-1		OUTLINE DRAWING

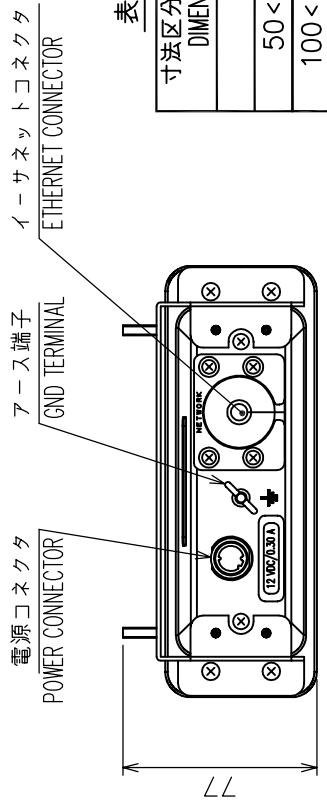
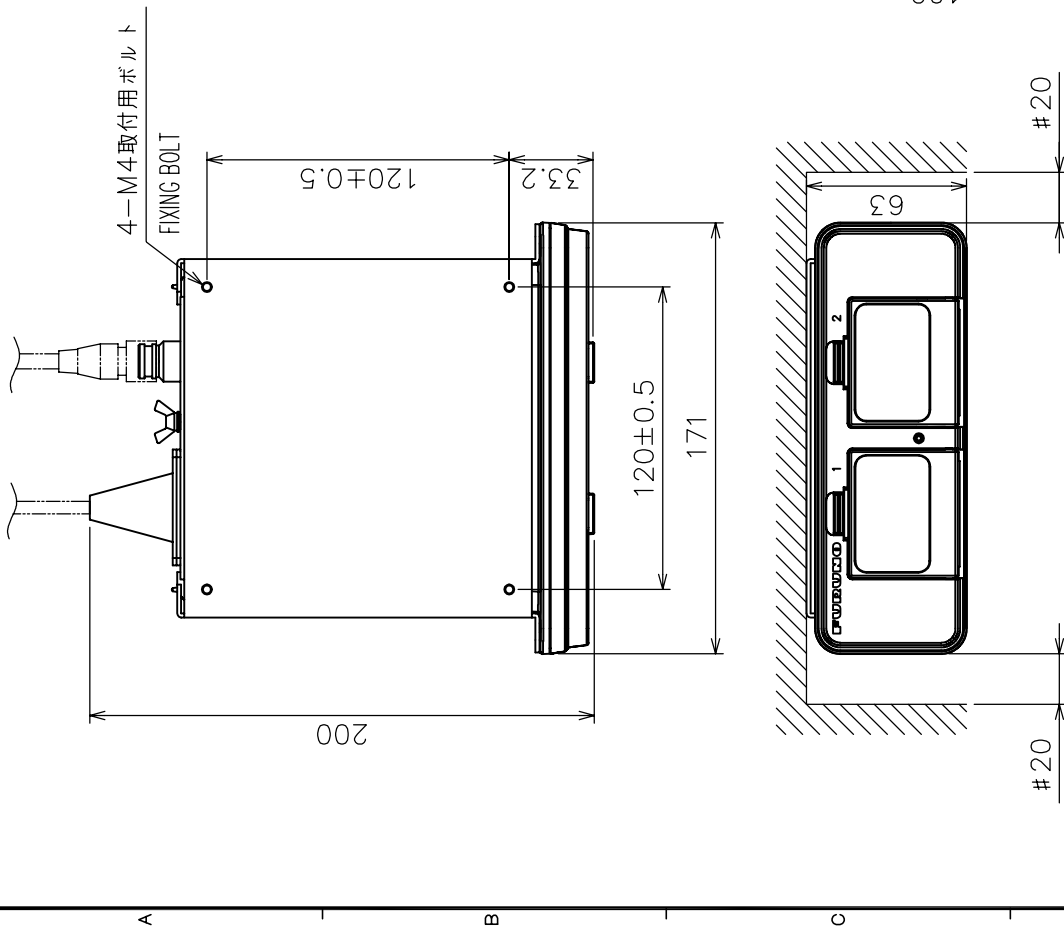
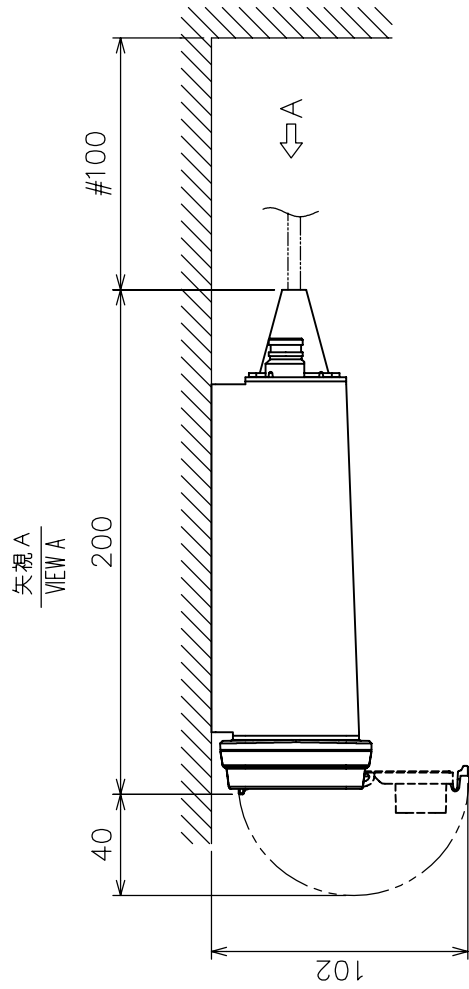

表 1 TABLE 1

寸法区分 (mm) DIMENSIONS (mm)	公差 (mm) TOLERANCE (mm)
L ≤ 50	± 1.5
50 < L ≤ 100	± 2.5
100 < L ≤ 500	± 3
500 < L ≤ 1000	± 4

矢視 A
VIEW A

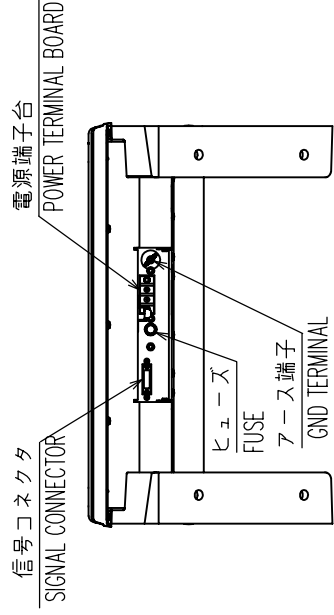
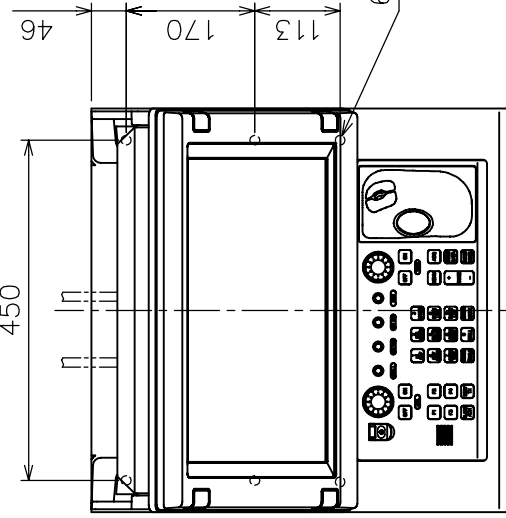
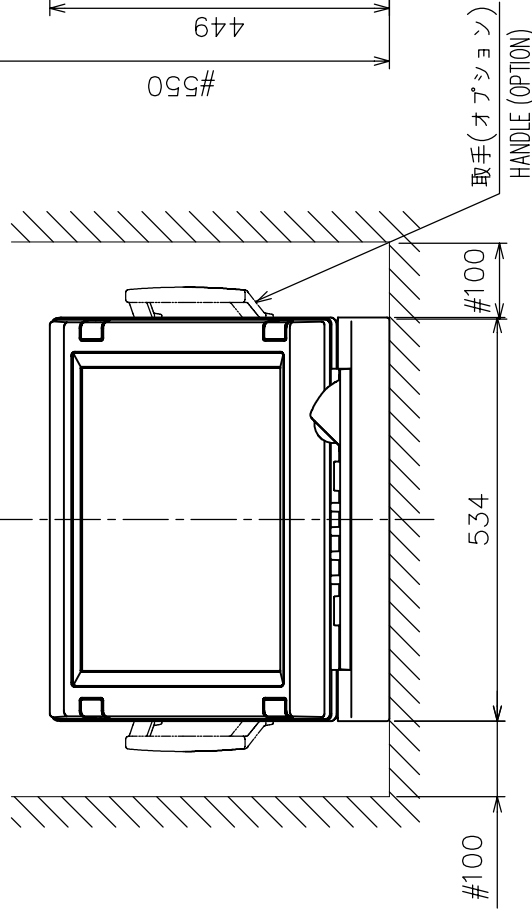
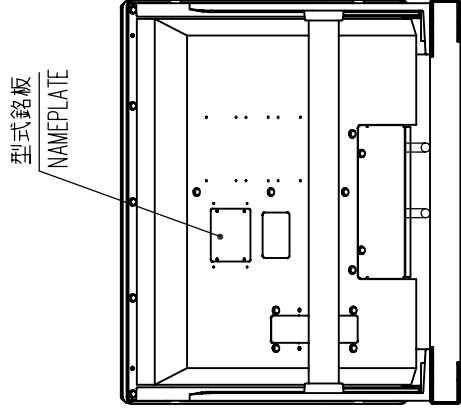
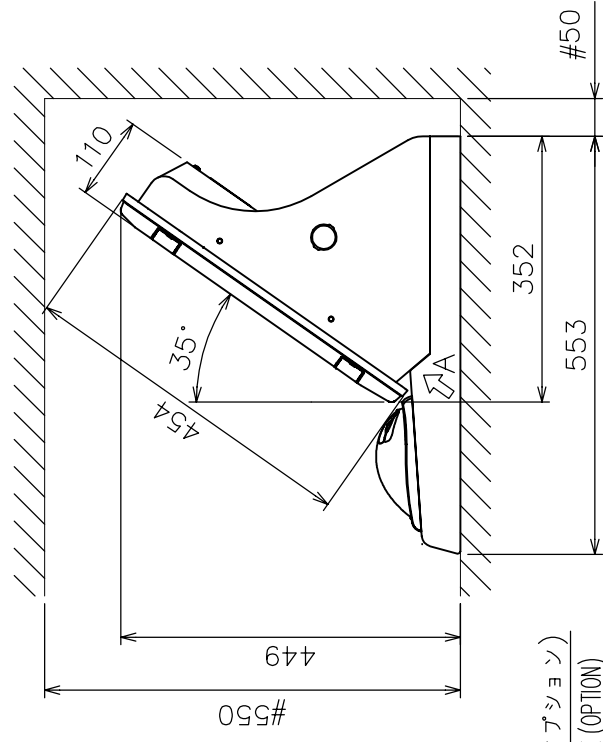

- 注記
- 1) # 印寸法は最小サービスクリアランスとする。
 - 2) 指定外の寸法公差は表 1 による。
 - 3) 取付用ネジは M10 ボルト、またはコーチボルト呼び径 9 を使用のこと。
 - 4) 質量は操作部ケーブル (10m) を含む。
- NOTE
1. # MINIMUM SERVICE CLEARANCE.
 2. TABLE 1 INDICATES TOLERANCE OF DIMENSIONS WHICH IS NOT SPECIFIED.
 3. USE M10 BOLTS OR COACH SCREWS φ9 FOR FIXING THE UNIT.
 4. MASS INCLUDES CONTROL CABLE (10m).

DRAWN	Mar. 18 '04	E. MIYOSHI	TITLE	MU-201CR w/ RCU-014
CHECKED		TAKAHASHI, T	名称	指示部 (連結タイプ)
APPROVED		Y. Hatai	外寸図	
SCALE	1/1.0	MASS 27 kg	NAME	DISPLAY UNIT (COMBINATION TYPE)
DWG. No.	C3519-G27-A	03-163-760G-2		OUTLINE DRAWING

表 1 TABLE 1

寸法区分 (mm) DIMENSIONS	公差 (mm) TOLERANCE
$L \leq 50$	± 1.5
$50 < L \leq 100$	± 2.5
$100 < L \leq 500$	± 3

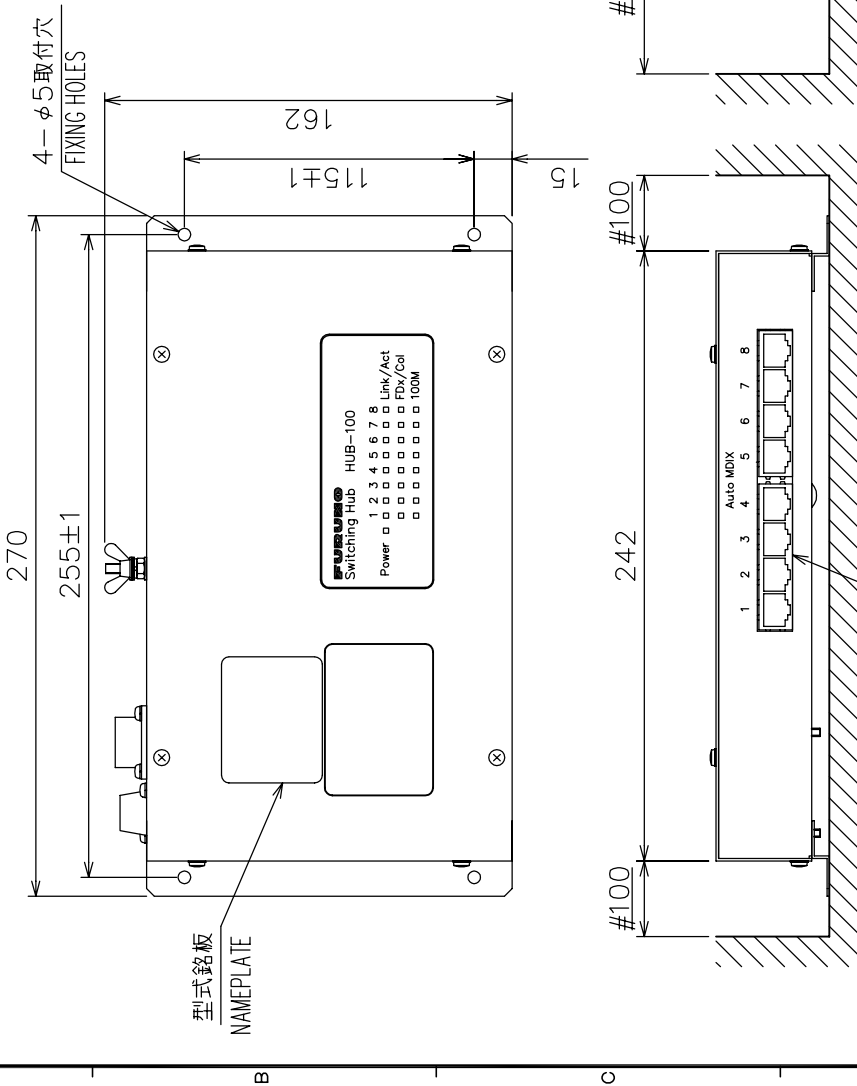

注 記

- 1) 取付ネジはトラスタップネジ呼び径4×16を使用のこと
- 2) 指定外寸法公差は表1による
- 3) #印寸法は最小サービス空間寸法とする

NOTE

1. USE TAPPING SCREWS 4x16 FOR FIXING THE UNIT.
2. TABLE 1 INDICATES TOLERANCE OF DIMENSIONS WHICH IS NOT SPECIFIED.
3. # MINIMUM SERVICE CLEARANCE.

DRAWN	Mar. 31 '04	T. YAMASAKI	TITLE	HUB-100
CHECKED	Mar. 31 '04	T. MATSUGUCHI	名称	イーサネットスイッチングハブ
APPROVED	Apr. 05 '04	マツグチ	外寸図	
SCALE	1/3	MASS 1.5 kg ±10%	NAME	SWITCHING HUB
DWG.No.	C3519-G18-B			OUTLINE DRAWING

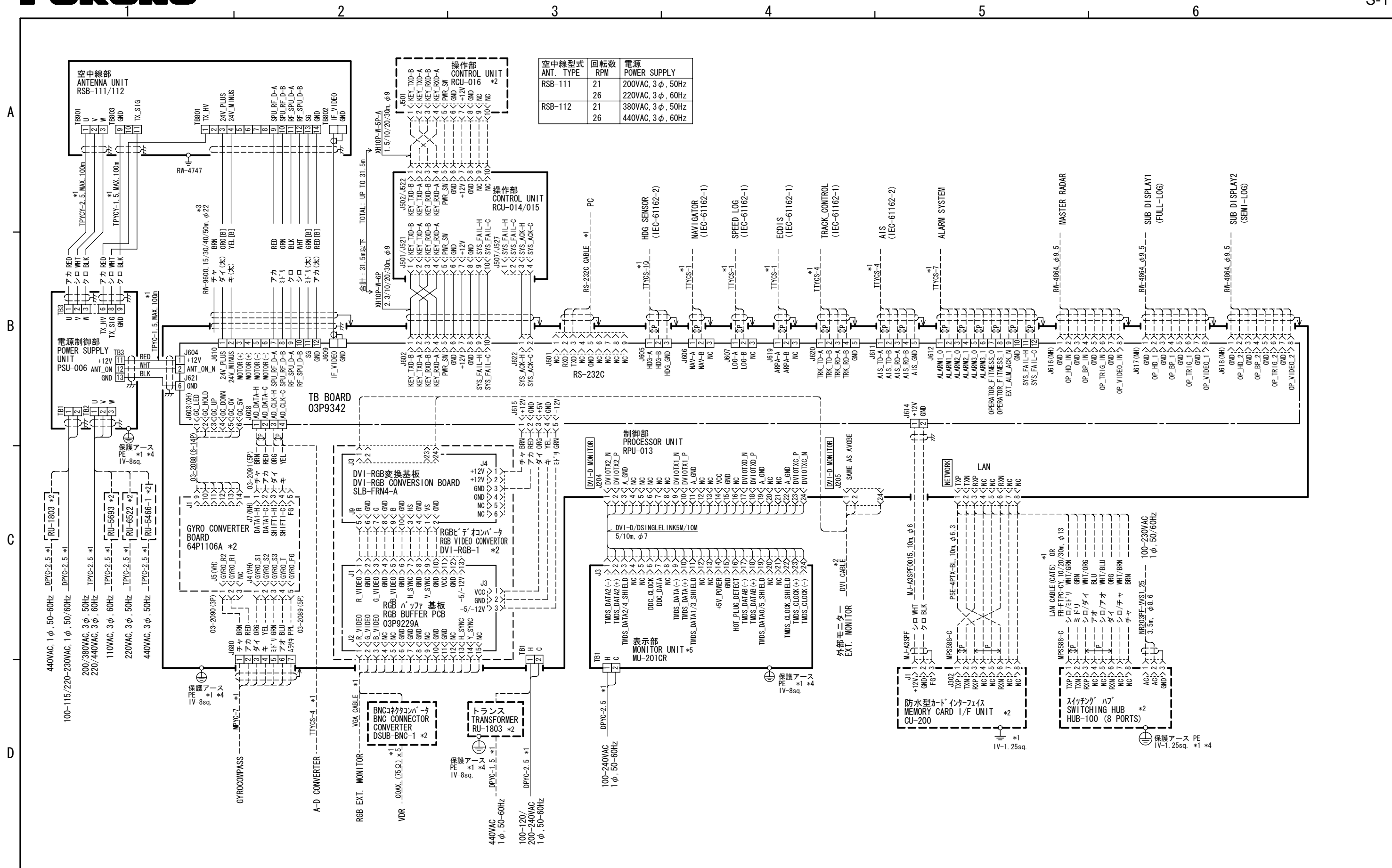

注記
 *1) 造船所手配。
 *2) オプション。
 *3) 最長 100m (延長するときは接続箱RJB-001が必要)。
 *4) 保護アース用ケーブルは緑/黄の絶縁線を使用のこと。
 *5) FAR-2167DS-BBのときは支給なし。

NOTES
 *1: SHIPYARD SUPPLY.
 *2: OPTION.
 *3: MAX. 100m. (JUNCTION BOX RJB-001 IS REQUIRED FOR EXTENSION)
 *4: USE GRN/YEL WIRE FOR PROTECTIVE EARTH.
 *5: NOT SUPPLIED FOR FAR-2167DS-BB.

DRAWN Oct. 6 '06 Maki	TYPE FAR-2167DS/2167DS-BB
CHECKED TAKAHASHI, T	名称 船舶用レーダー/ARPA
APPROVED Y. Hatai	相互結線図
SCALE MASS kg	NAME MARINE RADAR/ARPA
DWG. No. C3523-C01-B	INTERCONNECTION DIAGRAM